

# Low Voltage, Branch Circuit Rated Fuses

<b>Fuse Holder &amp; Block Selection Guide</b>	<b>Page</b> <b>8-10</b>
<b>Class Fuse Dimensions</b>	<b>11-12</b>
<b>Fuses By Fuse Class</b>	

Low Voltage  
Branch  
Circuit  
Fuses

<u>Class</u>	<u>Fuses</u>	<u>Volts</u>	
<b>CC</b> . . . . .	LP-CC . . . . .	600V . . . . .	19
	FNQ-R . . . . .	600V . . . . .	32
	KTK-R . . . . .	600V . . . . .	29
<b>G</b> . . . . .	SC . . . . .	600/480V . . .	35
<b>J</b> . . . . .	TCF* . . . . .	600V . . . . .	13-14
	LPJ-SP . . . . .	600V . . . . .	15
	LPJ-SPI indicator . . . . .	600V . . . . .	15
	<b>DFJ</b> . . . . .	<b>600V . . . . .</b>	<b>25</b>
	JKS . . . . .	600V . . . . .	26
<small>*Class J performance</small>			
<b>K5 &amp; H</b> . . . . .	NON . . . . .	250V . . . . .	36
	NOS . . . . .	600V . . . . .	36
<b>L</b> . . . . .	KRP-C_SP . . . . .	600V . . . . .	20-21
	KRP-CL . . . . .	600V . . . . .	21
	KLU . . . . .	600V . . . . .	30
	KTU . . . . .	600V . . . . .	30
<b>RK1</b> . . . . .	LPN-RK_SP . . . . .	250V . . . . .	16-18
	LPN-RK_SPI Indicator . . . . .	250V . . . . .	16-18
	LPS-RK_SP . . . . .	600V . . . . .	16-18
	LPS-RK_SPI Indicator . . . . .	600V . . . . .	16-18
	KTN-R . . . . .	250V . . . . .	27
KTS-R . . . . .	600V . . . . .	28	
<b>RK5</b> . . . . .	DLN-R . . . . .	250V . . . . .	31
	DLS-R . . . . .	600V . . . . .	31
	FRN-R . . . . .	250V . . . . .	22-23
	FRS-R . . . . .	600V . . . . .	24
<b>T</b> . . . . .	JJN . . . . .	300V . . . . .	33
	JJS . . . . .	600V . . . . .	34
<b>Plug Fuses</b>	W, SL, TL, S and T Series . . . . .	125V . . . . .	35-38

**RED** indicates **NEW** information

**Low Voltage, Branch Circuit Rated Fuses**

**Holders & blocks for branch circuit rated fuses**

Class	Fuses	Volts	Page
CC	LP-CC	600V .....	19
	FNQ-R	600V .....	32
	KTK-R	600V .....	29

**Holders**

- OPM-NG-SC3 3-pole, panel/DIN rail mount ..... 234
- OPM-1038R 3-pole, panel/DIN rail mount ..... 233
- OPM-1038RSW 3-pole w/ switch, panel/DIN rail mount .. 232
- CHCC\_D 1 to 3-pole, DIN rail mount ..... 239
- HPF-RR, front panel mount ..... 268
- HPS-RR, front panel mount ..... 268

**Blocks**

- BC Series, panel mount ..... 256

**Disconnects**

- Open
- CDF30CC\_3- & 4-pole, base & DIN rail mount ..... 313
- Enclosed
- EFC30\_3-, 4- & 6-pole, NEMA 1, 3, 4, 4X, 7 & 9, 12 .... 319



OPM-NG-SC3



OPM-1038R &  
OPM-1038RSW



CHCC\_D



HPF-RR



HPS-RR



BC Series



CFD30J3



FD400J3



EFJ30X-3PB6

Class	Fuses	Volts	Page
G	SC	600/480V .....	35

**Holders**

- HP Series front panel accessible, front panel mount ..... 268

**Blocks**

- BG Series, panel/DIN rail with adapters ..... 256
- G Series, panel/DIN rail with adapters ..... 256



HP Series



BG & G Series

Class	Fuses	Volts	Page
K5 & H	NON	250V .....	36
	NOS	600V .....	36

**Blocks**

- Modular Type Fuse Blocks 250/600V, panel mount ..... 257
- H250 Series 1 to 3-pole 250V, panel mount ..... 242
- H600 Series 1 to 3-pole 600V, panel mount ..... 245



Modular Type



H250 Series



H600 Series

# Low Voltage, Branch Circuit Rated Fuses

## Holders & blocks for branch circuit rated fuses

Low Voltage  
Branch  
Circuit  
Fuses

Class	Fuses	Volts	Page
L	KRP-C_SP	600V . . . . .	20
	KRP-CL	600V . . . . .	21
	KLU	600V . . . . .	30
	KTU	600V . . . . .	30

**Blocks**

- 51215 1-pole, panel mount\*
- 51235 3-pole, panel mount\*

\*Call our customer satisfaction team at 636-527-3877 for more information.



FD400J3



51215



51235

**Disconnects**

Open

FD800L\_601-800A, 2-, 3- & 4- pole, base & DIN rail mount . .312

Class	Fuses	Volts	Page
RK1	LPN-RK_SP	250V . . . . .	16
	LPS-RK_SP	600V . . . . .	16
	KTN-R	250V . . . . .	27
	KTS-R	600V . . . . .	28

**Blocks**

- R250 Series 1 to 3-pole 250V, panel mount . . . . .242
- R600 Series 1 to 3-pole 600V, panel mount . . . . .245



R250 Series



R600 Series

Class	Fuses	Volts	Page
RK5	FRN-R	250V . . . . .	22
	FRS-R	600V . . . . .	24
	DLN-R	250V . . . . .	31
	DLS-R	600V . . . . .	31

**Blocks**

- R250 Series 1 to 3-pole 250V, panel mount . . . . .242
- R600 Series 1 to 3-pole 600V, panel mount . . . . .245



R250 Series



R600 Series

Class	Fuses	Volts	Page
T	JJN	300V . . . . .	33
	JJS	600V . . . . .	34

**Blocks**

- BH Series modular-style, panel mount (<60A) . . . . .257
- T300 Series 1 to 4-pole 300V, panel mount . . . . .251
- T600 Series 1 to 3-pole 600V, panel mount . . . . .253

**Disconnects**

Open

• CDF30CC\_ 3- & 4-pole, base & DIN rail mount . . . . . 313

Enclosed

• EFC30\_ 3-, 4-, & 6-pole, NEMA 1, 3, 4, 4X, 7 & 9, 12 . . .319



BH Series



T300 Series



T600 Series

## Low Voltage, Branch Circuit Rated Fuses

### Holders & blocks for branch circuit rated fuses

Class	Fuses	Volts	Page
J	TCF*	600V .....	13
	LPJ-SP	600V .....	15
	JKS	600V .....	26

\*Class J performance

#### Holders

- TCFH CUBEFuse® holder, panel/DIN rail mount ..... 13-14
- CH Series Class J modular 1 to 3-pole, panel/DIN rail mount ..... 236
- Safety J™ Series modular holders, panel/DIN rail mount ..... 237

#### Blocks

- Modular Type Fuse Blocks 600V, panel mount ..... 257
- J600 Series, panel mount ..... 248
- JP Series pyramid blocks, panel mount ..... 250
- BH Series modular-style open blocks, panel mount ..... 257

#### Disconnects

- Open
- CFD\_ \_J\_ 0-100A, 3- & 4-pole, base & DIN rail mount ..... 315
  - FD\_00J\_ 0-800A, 2-, 3- & 4-pole, base & DIN rail mount Enclosed ..... 317
- Enclosed
- EFJ\_ 0\_ \_PB\_ 0-800A, 3-, 4- & 6-pole, NEMA 1, 3R, 4, 4X, 7 & 9, 12 ..... 319



TCFH CH Series Safety J™ Series Modular Type



J600 Series JP Series BH Series



CFD30J3 FD400J3 EFJ30X-3PB6

Class	Fuses	Volts	Page
Plug Fuses	W, SL, TL, S and T Series	125V .....	37-38

#### Box Cover Units

- Standard electrical box mounting ..... 258



Fuse Only With Grounded Outlet With Switch

#### Fuse Reducers For Class R Fuses 250V

Equipment Fuse Clip Amps	Desired Fuse (Case) Amp Size	Catalog No. (Pairs) 250V
60	30	No. 263-R
100	30	No. 213-R
	60	No. 216-R
200	60	No. 226-R
	100	No. 2621-R
400	100	No. 2641-R
	200	No. 242-R
600	100	No. 2661-R
	200	No. 2662-R
	400	No. 2664-R*

\*Single reducer only (pair not required).

#### Fuse Reducers For Class R Fuses 600V

Equipment Fuse Clip Amps	Desired Fuse (Case) Amp Size	Catalog No. (Pairs) 600V
60	30	No. 663-R
100	30	No. 216-R
	60	No. 616-R
200	60	No. 626-R
	100	No. 2621-R
400	100	No. 2641-R
	200	No. 642-R
600	100	No. 2661-R
	200	No. 2662-R
	400	No. 2664-R*

\*Single reducer only (pair not required).

Branch circuit rated fuse dimensions

Low Voltage  
Branch  
Circuit  
Fuses

Class J Dimensions - in (mm)

Low-Peak® and Limitron® Fuses  
LPJ & JKS — 600V

Amp Range	A	B	C	D	E	F	G	H	I
1-30	2.25 (57.2)	0.81 (20.6)	—	—	0.50 (12.7)	—	—	—	—
35-60	2.38 (60.3)	1.06 (27.0)	—	—	0.63 (15.9)	—	—	—	—
65-100	4.63 (117.5)	1.13 (28.6)	3.63 (92.1)	2.63 (66.7)	1.00 (25.4)	0.75 (28.6)	0.13 (3.2)	0.41 (10.4)	0.28 (7.1)
110-200	5.75 (146.1)	1.63 (41.4)	4.38 (111.1)	3.00 (76.2)	1.38 (34.9)	1.13 (28.6)	0.19 (4.8)	0.38 (9.5)	0.28 (7.1)
225-400	7.12 (181.0)	2.11 (53.6)	5.25 (133.3)	1.51 (38.3)	1.87 (47.6)	1.62 (41.2)	0.25 (6.4)	0.56 (14.2)	0.40 (10.3)
450-600	8.00 (203.2)	2.60 (66.0)	6.00 (152.4)	1.52 (38.6)	2.12 (54.0)	2.00 (50.8)	0.53 (13.5)	0.72 (18.3)	0.53 (13.5)

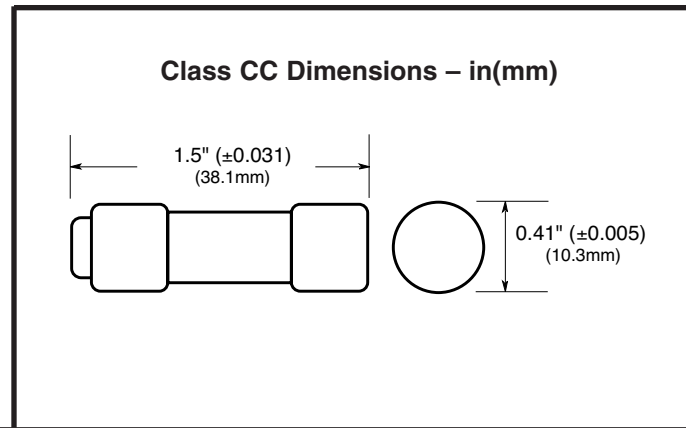
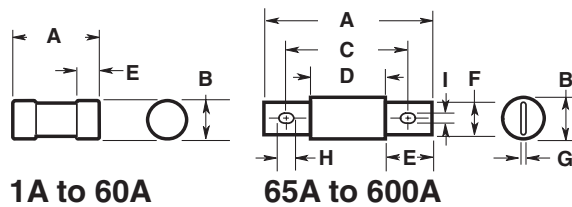

CLASS RK1 & RK5 Dimension - in (mm)

Basic dimensions are same as Class H (formerly NEC) One-Time (NON & NOS) and Superlag Renewable RES & REN fuses.  
NOTE: These fuses can be used to replace existing Class H, RK1 and RK5 fuses relating to dimensional compatibility.

Ferrule Styles

Amp Range	250V		600V	
	A	B	A	B
1/10-30	2 (50.8)	0.56 (14.3)	5.0 (127.0)	0.81 (20.6)
35-60	3 (76.2)	0.81 (20.6)	5.5 (139.7)	1.06 (27.0)

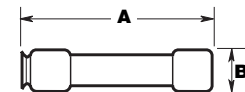

Fusetron® — (FRN-R & FRS-R) & Limitron® — (KTN-R & KTS-R)

Amp Range	250V		600V	
	A	B	A	B
70-100	5.88 (149.2)	1.06 (26.9)	7.88 (200.0)	1.34 (34.0)
110-200	7.13 (181.0)	1.56 (39.6)	9.63 (244.5)	1.84 (46.7)
225-400	8.63 (219.1)	2.06 (52.3)	11.63 (295.3)	2.59 (65.8)
450-600	10.38 (263.5)	2.59 (65.8)	13.38 (339.7)	3.13 (79.5)

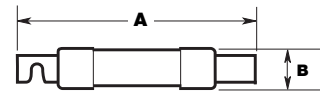

Low-Peak® — (LPN-RK & LPS-RK)

Amp Range	250V		600V	
	A	B	A	B
70-100	5.88 (149.2)	1.16 (29.5)	7.88 (200.0)	1.16 (29.5)
110-200	7.13 (181.0)	1.66 (42.2)	9.63 (244.5)	1.66 (42.2)
225-400	8.63 (219.1)	2.38 (60.5)	11.63 (295.3)	2.38 (60.5)
450-600	10.38 (263.5)	2.88 (73.2)	13.38 (339.7)	2.88 (73.2)

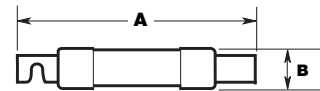

# Branch circuit rated fuse dimensions

## Class L Dimensions - in (mm)

### Low-Peak® and Limitron® Fuses

Amp Range	A	B	C1	C2	D	F	G	I	J1	J2	J3	J4
601-800	8.63 (219.1)	2.40 (61.0)	6.75 (171.5)	5.75 (146.1)	3.75 (95.3)	2.00 (50.8)	0.38 (9.5)	0.63 (15.9)	—	—	—	—
801-1200	10.75 (273.1)	2.40 (61.0)	6.75 (171.5)	5.75 (146.1)	3.75 (95.3)	2.00 (50.8)	0.38 (9.5)	0.63 (15.9)	—	—	—	—
1350-1600	10.75 (273.1)	3.00 (76.2)	6.75 (171.5)	5.75 (146.1)	3.75 (95.3)	2.38 (60.3)	0.44 (11.1)	0.63 (15.9)	—	—	—	—
1800-2000	10.75 (273.1)	3.50 (88.9)	6.75 (171.5)	5.75 (146.1)	3.75 (95.3)	2.75 (69.9)	0.50 (12.7)	0.63 (15.9)	—	—	—	—
2001-2500	10.75 (273.1)	4.80 (122.0)	6.75 (171.5)	5.75 (146.1)	3.75 (95.3)	3.50 (88.9)	0.75 (19.1)	0.63 (15.9)	1.75 (44.5)	1.38 (34.9)	0.88 (22.2)	0.81 (20.6)
3000	10.75 (273.1)	5.00 (127.0)	6.75 (171.5)	5.75 (146.1)	3.75 (95.3)	4.00 (101.6)	0.75 (19.1)	0.63 (15.9)	1.75 (44.5)	1.38 (34.9)	0.88 (22.2)	0.81 (20.6)
3500-4000	10.75 (273.1)	5.75 (146.1)	6.75 (171.5)	5.75 (146.1)	3.75 (95.3)	4.75 (120.7)	0.75 (19.1)	0.63 (15.9)	1.75 (44.5)	1.38 (34.9)	1.63 (41.3)	0.88 (22.2)
4500-5000	10.75 (273.1)	6.25 (158.8)	6.75 (171.5)	5.75 (146.1)	3.75 (95.3)	5.25 (133.4)	1.00 (25.4)	0.63 (15.9)	1.75 (44.5)	1.38 (34.9)	1.63 (41.3)	0.88 (22.2)
6000	10.75 (273.1)	7.13 (181.0)	6.75 (171.5)	5.75 (146.1)	3.75 (95.3)	5.75 (146.1)	1.00 (25.4)	0.63 (15.9)	1.75 (44.5)	1.38 (34.9)	1.63 (41.3)	0.88 (22.2)

NOTE: KRP-CL (150A to 600A) fuses have same dimensions as 601-800A case size. KTU (200-600A) have same dimensions, except tube 3" length x 2" diameter (76.2 x 50.8mm); terminal 1½" width x 1¼" thick (41.3 x 31.8mm).

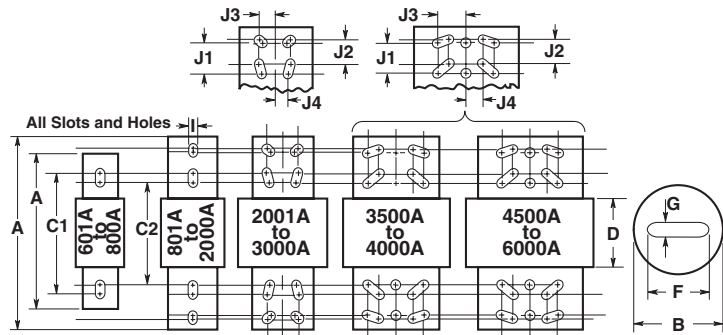

## Class T Dimensions - in (mm)

### T-Tron® Fuses

#### JJN — 300V

Amp Range	A	B	C	D
1-30	0.88 (22.2)	0.41 (10.3)	—	—
35-60	0.88 (22.2)	0.56 (14.3)	—	—
70-100	2.16 (54.8)	0.75 (19.1)	1.56 (39.7)	0.84 (21.4)
110-200	2.44 (61.9)	0.88 (22.2)	1.69 (42.9)	0.84 (21.4)
225-400	2.75 (69.9)	1.00 (25.4)	1.84 (46.8)	0.86 (21.8)
450-600	3.06 (77.8)	1.25 (31.8)	2.03 (51.6)	0.88 (22.2)
601-800	3.38 (85.7)	1.75 (44.5)	2.22 (56.4)	0.89 (22.6)
801-1200	4.00 (101.6)	2.00 (50.8)	2.53 (64.3)	1.08 (27.4)

#### JJS — 600V

Amp Range	A	B	C	D
1-30	1.50 (38.1)	0.56 (14.3)	—	—
35-60	1.56 (39.7)	0.81 (20.6)	—	—
70-100	2.95 (75.0)	0.75 (19.1)	2.36 (59.9)	1.64 (41.7)
110-200	3.25 (82.6)	0.88 (22.2)	2.50 (63.5)	1.66 (42.1)
225-400	3.63 (92.1)	1.00 (25.4)	2.72 (69.1)	1.73 (44.1)
450-600	3.98 (101.2)	1.25 (31.8)	2.96 (75.0)	1.78 (45.2)
601-800	4.33 (109.9)	1.75 (44.5)	3.17 (80.6)	1.88 (47.6)

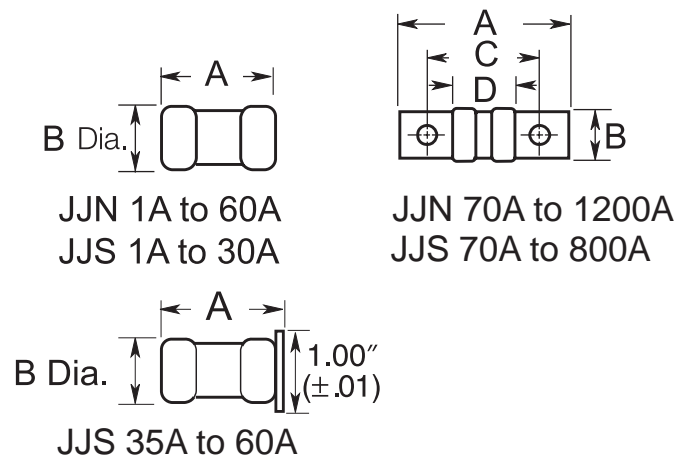

# CUBEFuse® finger-safe fuse and fuse holder system

Low Voltage  
Branch  
Circuit  
Fuses

**TCF (fuse) Class J**  
**TCFH (holder)**



**Specifications**

**Description:** Finger-safe fuse and fuse holder system; dual-element, time-delay fuse; 10 seconds minimum operating time at 500% rated amps.

**Dimensions:** See Dimensions illustration.

**Construction:**

**Poles:** 1 (gangable to 2- and 3-pole)

**Ratings:**

- Volts — 600Vac (or less)
- 300Vdc (or less), 100,000A IR
- Amps — 1-100A
- IR — 300,000A RMS Sym. (UL)
- 200,000A RMS Sym. (CSA)

**Agency Information:** CE, UL Listed Special Purpose Fuse: Guide JFHR, File E56412, CSA Certified Fuse: Class 1422- 02, File 53787, UL Listed Fuse holder: Guide IZND, File E214079, CSA Certified Fuse holder: Class 6225-01, File 47235.

**Features and Benefits**

- Separate overload and short-circuit elements provide time delay for sizing of high inrush loads linked with Class J current limitation.
- Selective coordination ratio of 2:1 (within Low-Peak fuse family) prevents electrical shutdowns from extending beyond the failed circuit.
- Smallest footprint of any Class CC, J, T or RK fuse provides substantial space savings and installation flexibility.
- IEC 60529 and IP-20 finger-safe rating provides enhanced workplace safety.

**Typical Applications**

- Electrical Panelboards
- Machinery Disconnects
- Industrial Control
- Required Finger-Safe Systems

**Fuse Catalog Numbers (Amps)**

TCF1*	TCF17-½	TCF40	TCF80
TCF3*	TCF20	TCF45	TCF90
TCF6	TCF25	TCF50	TCF100
TCF10	TCF30	TCF60	
TCF15	TCF35	TCF70	

\*Minimum 75 Vac/Vdc required for indication.

**Fuse Holder Catalog Numbers**

Catalog Numbers	Amp Range	Wire Range** Single Wire	Dual Wire
TCFH30	1-30	14 to 8 AWG CU	14 AWG CU
TCFH60	35-60	14 to 4 AWG CU	10 to 6 AWG CU
TCFH100	70-100	10 to 1 AWG CU	6 AWG CU

\*\*75°C minimum CU wire only.

**Dimensions - in (mm)**

Dimension	30A	60A	100A
A	1.88 (47.75)	2.13 (54.10)	3.01 (76.45)
B	0.75 (19.05)	1.00 (25.40)	1.00 (25.40)
C	1.00 (25.40)	1.13 (28.58)	1.26 (32.00)
D	0.31 (7.94)	0.44 (11.11)	0.57 (14.48)
E	0.04 (1.02)	0.04 (1.02)	0.06 (1.60)
F	0.63 (15.88)	0.63 (15.88)	0.63 (15.88)
G	0.27 (6.86)	0.38 (9.65)	0.39 (9.93)
H	2.30 (58.42)	2.60 (66.04)	2.91 (73.91)
I	0.76 (19.30)	1.03 (26.16)	1.05 (26.75)
J	1.27 (32.18)	1.53 (38.86)	2.01 (51.05)
K	0.15 (3.81)	0.17 (4.32)	0.16 (4.06)
L	N/A	N/A	0.80 (20.32)
M	N/A	N/A	2.51 (63.75)

See next page (page 14) for dimensions illustration and curves.

# CUBEFuse® finger-safe fuse and fuse holder system

## Dimensions for CUBEFuse® Fuse and Fuse Holder

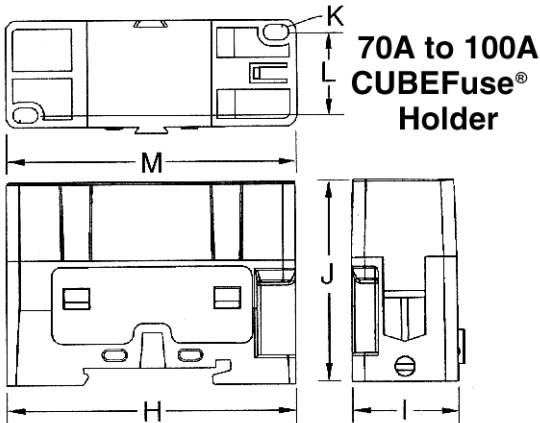
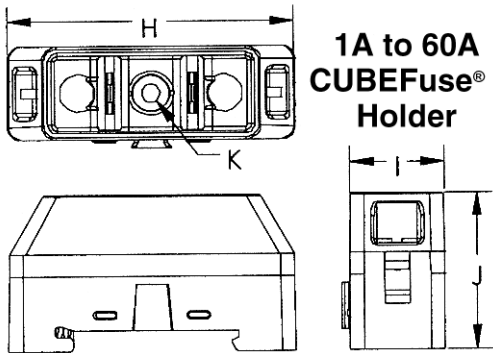
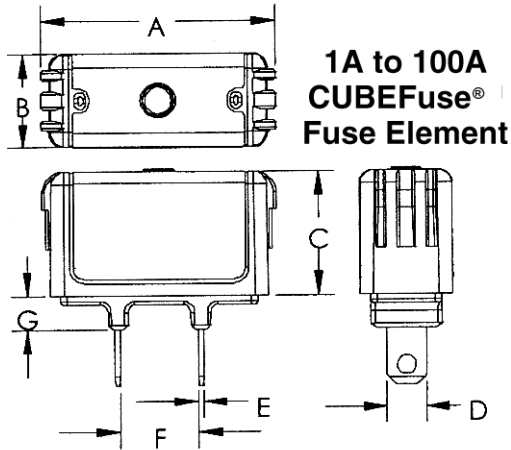

## Time-Current Characteristic Curves—Average Melt

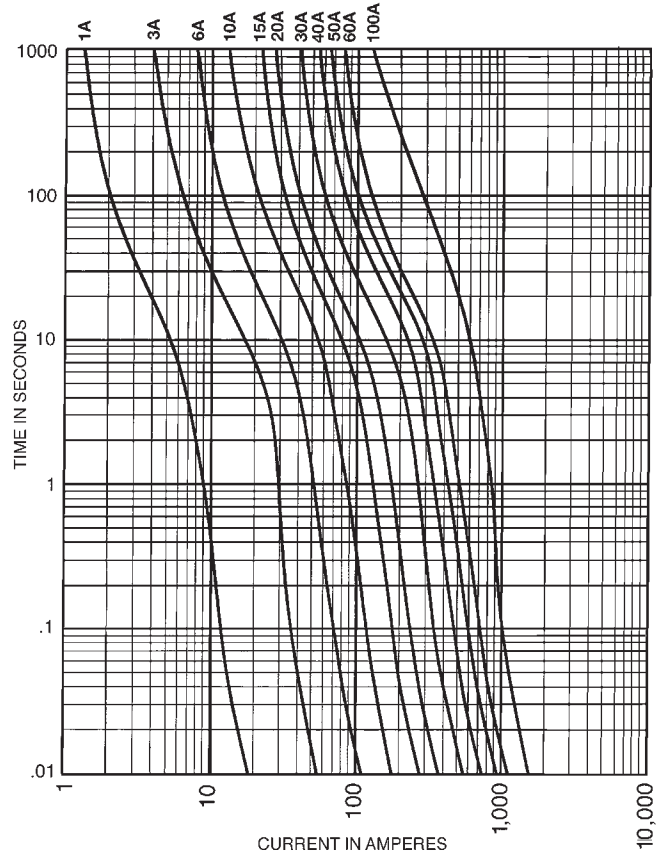

## Current Limitation Curves

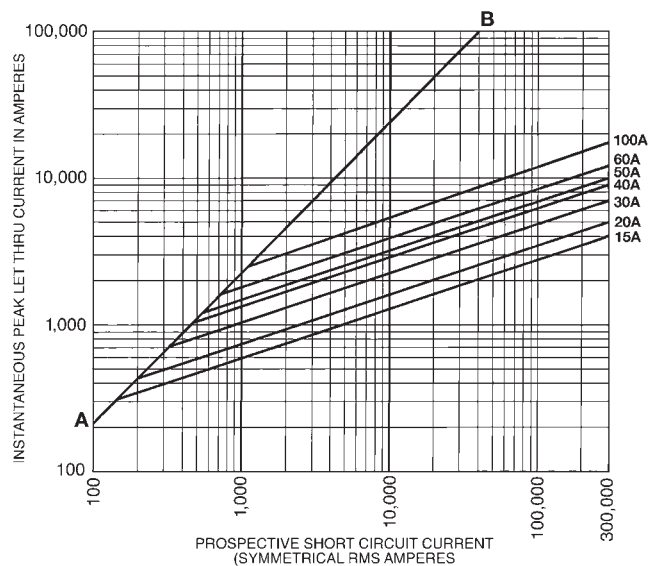

# Low Voltage, Branch Circuit Rated Fuses

## Low-Peak® dual-element, time-delay fuses

Low Voltage  
Branch  
Circuit  
Fuses

### LPJ\_SP Class J

**Now Available  
With Optional  
Indication**



#### Specifications

##### Description:

Dual-element, time-delay fuse;  
10 seconds (minimum) at 500% rated amps. Now  
available with optional permanent indication on  
select ratings (see Catalog Numbers table).

**Dimensions:** See page 11 for Class J dimensions.

**Construction:** Copper fuse element.

##### Ratings:

- Volts — 600Vac (or less)
- 300Vdc (or less)
- Amps — 1-600A
- IR — 300,000A RMS Sym.
- 100,000A dc

**Agency Information:** CE, UL Listed - Special Purpose\*,  
Guide JFHR, File E56412, CSA Certified (200,000 AIR)  
Class J per CSA-22.2 No. 248.8, Class 1422-02, File 53787.

#### Features and Benefits

- Separate overload and short-circuit elements provide time delay for sizing of high inrush loads linked with Class J current limitation.
- Selective coordination ratio of 2:1 (within Low-Peak fuse family) prevents electrical shutdowns from extending beyond the failed circuit.
- Series combination ratings with branch circuit breakers allows broad range of coverage, independent of breaker manufacturer.

#### Typical Applications

- Power Panelboards
- Branch Circuit Breaker Panelboard Mains
- Machinery Disconnects
- Industrial Control

#### Catalog Numbers (Amps)

LPJ-1SP	LPJ-4 1/2SP	LPJ-25SP**	LPJ-125SP**
LPJ-1 1/4SP	LPJ-5SP	LPJ-30SP**	LPJ-150SP**
LPJ-1 1/2SP	LPJ-5 5/8SP	LPJ-35SP**	LPJ-175SP**
LPJ-1 3/4SP	LPJ-6SP**	LPJ-40SP**	LPJ-200SP**
LPJ-2SP	LPJ-7SP**	LPJ-45SP**	LPJ-225SP**
LPJ-2 1/2SP	LPJ-8SP**	LPJ-50SP**	LPJ-250SP**
LPJ-2 3/4SP	LPJ-9SP**	LPJ-60SP**	LPJ-300SP**
LPJ-2 5/8SP	LPJ-10SP**	LPJ-70SP**	LPJ-350SP**
LPJ-3SP	LPJ-12SP**	LPJ-80SP**	LPJ-400SP**
LPJ-3 1/4SP	LPJ-15SP**	LPJ-90SP**	LPJ-450SP**
LPJ-3 1/2SP	LPJ-17 1/2SP**	LPJ-100SP**	LPJ-500SP**
LPJ-4SP	LPJ-20SP**	LPJ-110SP**	LPJ-600SP**

\*Meets all performance requirements of UL Standard 248-8 for Class J fuses.  
\*\*Available with optional permanent replace fuse indication. To order, place "I" at end of catalog number. Example: LPJ-6SPI.  
Available with silver plated terminals. Add SP/ in front of Catalog Number.

**Data Sheets: 1006 (0-60) and 1007 (70-600)**  
**With indication 1062 (6-60) and 1063 (70-600)**

#### Time-Current Characteristic Curves—Average Melt

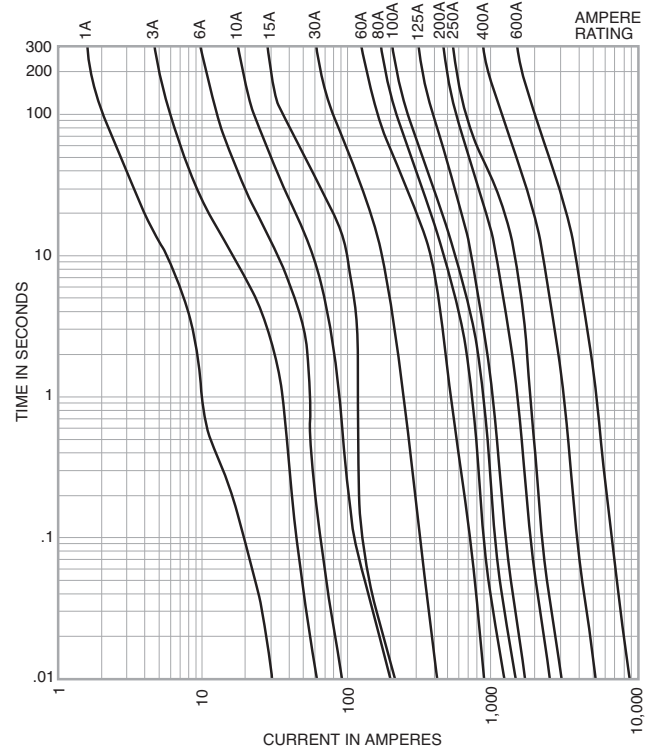

#### Current Limitation Curves

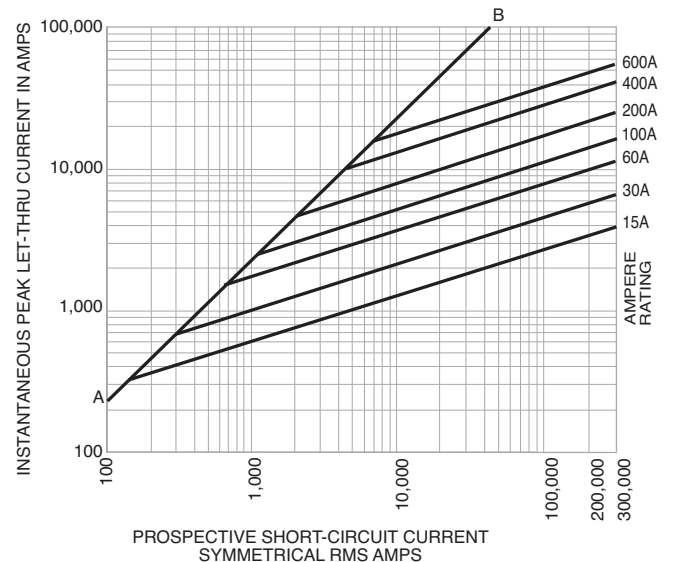

**Recommended Fuse Holders & Blocks For Class J 600V Fuses**  
• See page 10

## Low-Peak® dual-element, time-delay fuses

### LPN-RK\_SP (250V) Class RK1

### LPS-RK\_SP (600V) Class RK1

**Now Available  
With Optional  
Indication**



#### Specifications

##### Description:

Current-limiting, dual-element, time-delay fuse; 10 seconds (minimum) at 500% rated amps (8 seconds for 0-30A sizes). Now available with optional permanent indication on select ratings (see Catalog Numbers table).

**Dimensions:** See page 11 for Class RK1 dimensions.

**Construction:** Copper fuse element.

#### Ratings:

Volts **LPN-RK:**

- 250Vac (or less)
- 125Vdc (0-60A)
- 250Vdc (70-600A)

**LPS-RK:**

- 600Vac (or less)
- 300Vdc

Amps — 1/10-600A

- IR — 300,000A RMS Sym.
- 100,000A dc

**Agency Information:** CE, UL Listed – Special Purpose\*, Guide JFHR, File E56412, CSA Certified (200,000 AIR), Class RK1 per CSA C22.2, No. 248.12, Class 1422-02, File 53787.

#### Features and Benefits

- Separate overload and short-circuit elements provide time delay for close sizing of high inrush loads linked with K1 current-limitation and selective coordination ratio of 2:1 (within Low-Peak fuse family) prevents widespread blackouts.
- Inventory consolidation of Class RK1, RK5 and H fuses for reduced SKU investment and minimizing potential for misapplying fuse.
- 300,000A RMS symmetrical interrupting rating provides adequate ratings without obsolescence for all electrical systems, big or small.
- Insulated end caps reduces exposure to live parts and extends air gap to distance between blades of adjacent mounted fuses or to housing.

**Data Sheets:** LPN-RK — 1003 (0-60) and 1004 (70-600)  
 LPN-RK with indication — 1066 (70-600)  
 LPS-RK — 1001 (0-60) and 1002 (70-600)  
 LPS-RK with indication — 1061 (0-60) and 1064 (70-600)

#### Typical Applications

- Large Distribution Switchboards
- Power Panelboards
- Motor Control Centers
- Machinery Disconnect Switches

#### LPN Catalog Numbers (Amps) (250Vac/125Vdc)

LPN-RK-1/10SP	LPN-RK-3 1/2SP	LPN-RK-60SP**
LPN-RK-15/100SP	LPN-RK-4SP	LPN-RK-70SP***
LPN-RK-3/10SP	LPN-RK-4 1/2SP	LPN-RK-80SP**
LPN-RK-3/10SP	LPN-RK-5SP	LPN-RK-90SP**
LPN-RK-1/2SP	LPN-RK-5 1/2SP	LPN-RK-100SP**
LPN-RK-1/2SP	LPN-RK-6SP	LPN-RK-110SP**
LPN-RK-5/10SP	LPN-RK-6 1/2SP	LPN-RK-125SP**
LPN-RK-3/10SP	LPN-RK-8SP	LPN-RK-150SP**
LPN-RK-1SP	LPN-RK-9SP	LPN-RK-175SP**
LPN-RK-1 1/2SP	LPN-RK-10SP	LPN-RK-200SP**
LPN-RK-1 1/2SP	LPN-RK-12SP	LPN-RK-225SP**
LPN-RK-1 1/2SP	LPN-RK-15SP	LPN-RK-250SP**
LPN-RK-1 1/2SP	LPN-RK-17 1/2SP	LPN-RK-300SP**
LPN-RK-1 1/2SP	LPN-RK-20SP	LPN-RK-350SP**
LPN-RK-2SP	LPN-RK-25SP	LPN-RK-400SP**
LPN-RK-2 1/2SP	LPN-RK-30SP	LPN-RK-450SP**
LPN-RK-2 1/2SP	LPN-RK-35SP**	LPN-RK-500SP**
LPN-RK-2 1/2SP	LPN-RK-40SP**	LPN-RK-600SP**
LPN-RK-3SP	LPN-RK-45SP**	
LPN-RK-3 1/2SP	LPN-RK-50SP**	

\*Meets all performance requirements of UL Standard 248-12 for Class RK1 fuses.

\*\*Available with optional permanent indication. To order, place "I" at end of Catalog Number.

Example: LPN-RK-35SP1.

0-60A fuses available with Nickel plate option. (Ex: LPS-RK30SPNP) 70-600A fuses available with Tin plate option. Example: LPS-RK-100SP-TP.

#### LPS Catalog Numbers - (Amps) (600Vac/300Vdc)

LPN-RK-1/10SP	LPS-RK-2 1/2SP	LPS-RK-12SP**	LPS-RK-110SP**
LPN-RK-3/10SP	LPS-RK-2 1/2SP	LPS-RK-15SP**	LPS-RK-125SP**
LPN-RK-3/10SP	LPS-RK-3SP	LPS-RK-17 1/2SP**	LPS-RK-150SP**
LPN-RK-1/2SP	LPS-RK-3 1/2SP	LPS-RK-20SP**	LPS-RK-175SP**
LPN-RK-1/2SP	LPS-RK-3 1/2SP	LPS-RK-25SP**	LPS-RK-200SP**
LPN-RK-5/10SP	LPS-RK-4SP	LPS-RK-30SP**	LPS-RK-225SP**
LPN-RK-3/10SP	LPS-RK-4 1/2SP	LPS-RK-35SP**	LPS-RK-250SP**
LPN-RK-1SP	LPS-RK-5SP	LPS-RK-40SP**	LPS-RK-300SP**
LPN-RK-1 1/2SP	LPS-RK-5 1/2SP	LPS-RK-45SP**	LPS-RK-350SP**
LPN-RK-1 1/2SP	LPS-RK-6SP**	LPS-RK-50SP**	LPS-RK-400SP**
LPN-RK-1 1/2SP	LPS-RK-6 1/2SP**	LPS-RK-60SP**	LPS-RK-450SP**
LPN-RK-1 1/2SP	LPS-RK-7SP**	LPS-RK-70SP**	LPS-RK-500SP**
LPN-RK-1 1/2SP	LPS-RK-8SP**	LPS-RK-80SP**	LPS-RK-600SP**
LPN-RK-1 1/2SP	LPS-RK-9SP**	LPS-RK-90SP**	
LPN-RK-2 1/2SP	LPS-RK-10SP**	LPS-RK-100SP**	

\*Meets all performance requirements of UL Standard 248-12 for Class RK1 fuses.

\*\*Available with optional permanent replace fuse indication. To order, place "I" at end of Catalog Number. Example: LPS-RK-15SP1.

#### Recommended Fuse Holders & Blocks For Class RK1 600V & 250V Fuses

- See page 9

Low-Peak® dual-element, time-delay fuses

Time-Current Characteristic Curves—Average Melt

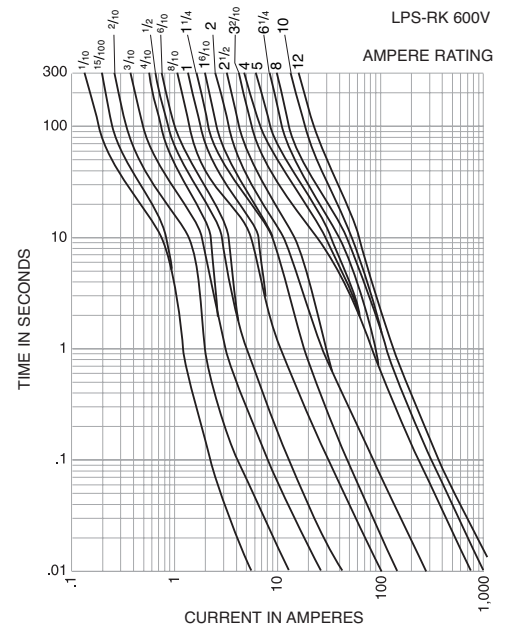
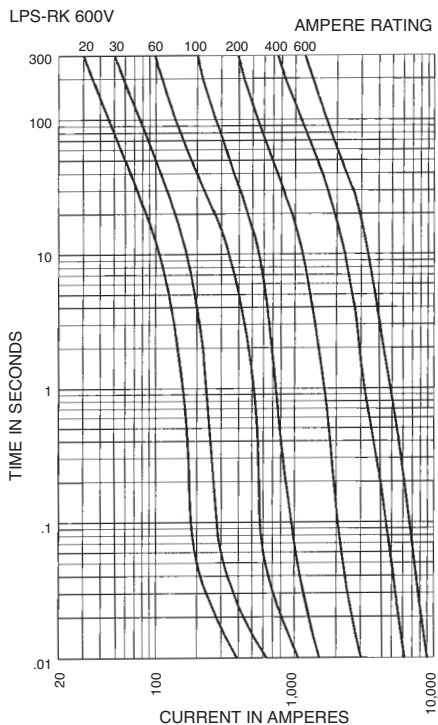
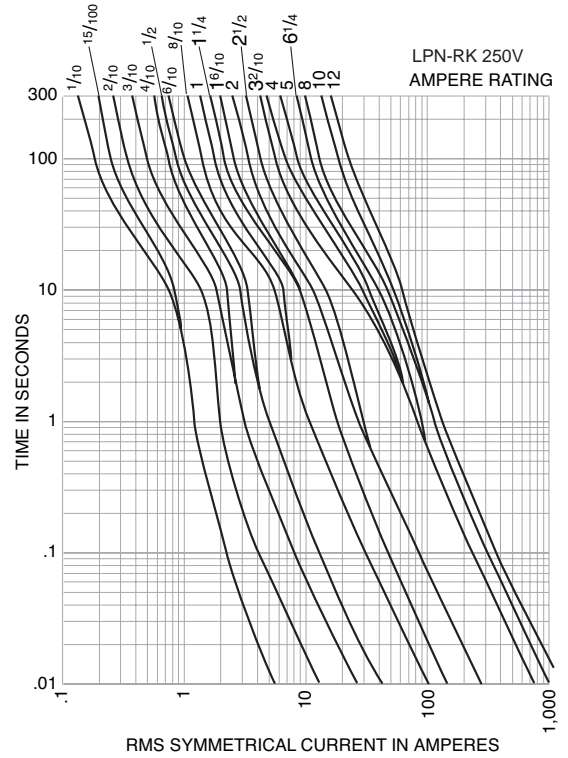
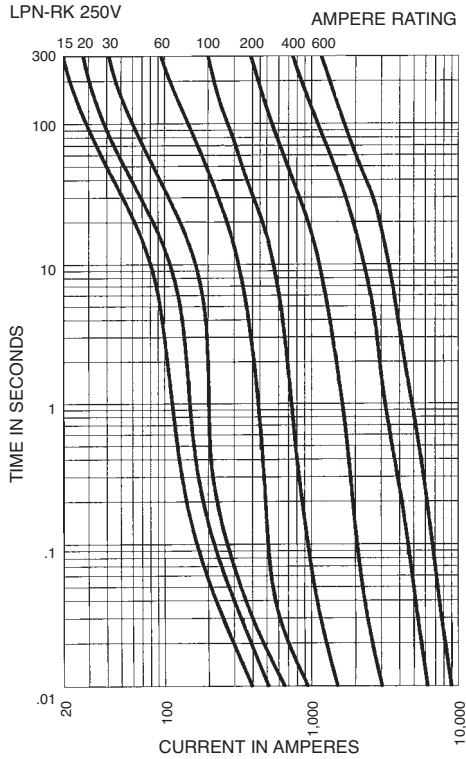

Data Sheets: LPN-RK — 1003 (0-60) and 1004 (70-600)  
Data Sheets: LPS-RK — 1001 (0-60) and 1002 (70-600)

Recommended Fuse Holders & Blocks For Class RK1 600V & 250V Fuses  
• See page 9

**Low Voltage, Branch Circuit Rated Fuses**

**Low-Peak® dual-element, time-delay fuses**

**Current Limitation Curves—LPN-RK (250V)**

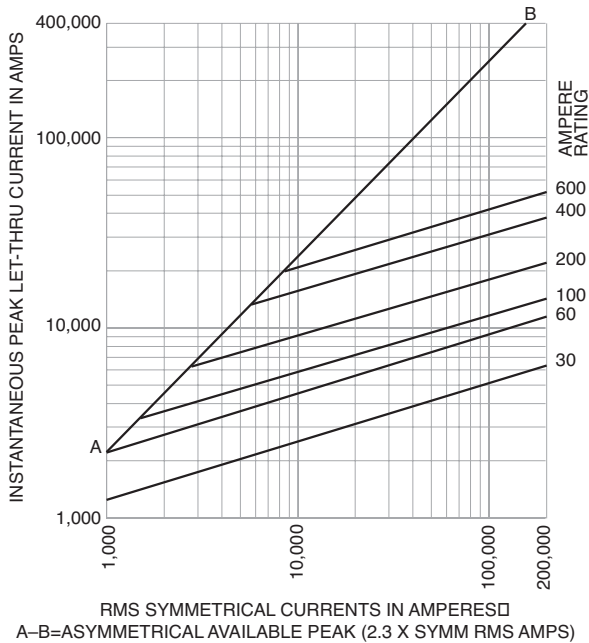

**Current Limitation Curves—LPS-RK (600V)**

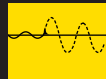
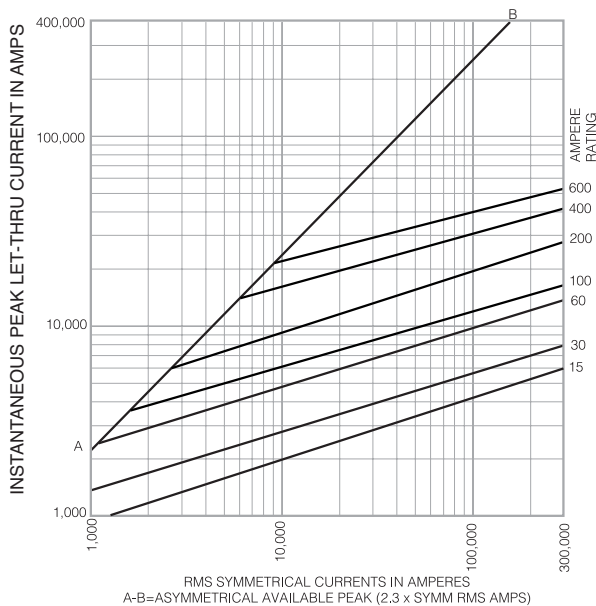

**Did You Know?**

**Manhattan's Biggest Building Project Protected by Cooper Bussmann® Low-Peak® Fuses**



New York City's landmark AOL Time Warner Center is protected by a vast array of Cooper Bussmann products. The \$1.7 billion, twin-towered, glass-walled complex rises 750 feet and measures 2.8 million square feet. The electrical circuit protection system has 25 switchboards (1200A - 4000A) all containing fusible switches, 500 panelboards (100A - 1600A), 75 plug-in busway switches (100A - 600A), and more than 1900 Cooper Bussmann Class J Low-Peak® fuses. Cooper Bussmann LPJ fuses were used because of the superior series-ratings available using Class J fuses with downstream circuit breaker panels.

Fuses were selected by the consulting engineer for all switchboards, power panels and busway switches because of the high available short circuit currents and the need for selective coordination of overcurrent protective devices (a requirement of the New York City Electrical Code) so the electrical system does not have a "blackouts."

**Data Sheets: LPN-RK — 1003 (0-60) and 1004 (70-600)**  
**Data Sheets: LPS-RK — 1001 (0-60) and 1002 (70-600)**

**Recommended Fuse Holders & Blocks For Class RK1 600V & 250V Fuses**

• See page 9

# Low-Peak® time-delay, rejection-type fuses

Low Voltage  
Branch  
Circuit  
Fuses

## LP-CC Class CC

### Specifications

**Description:** Time-delay, current-limiting, rejection-type fuse – 12 seconds (minimum) at 200% rated amps.

**Dimensions:** 1 1/2" x 1 1/2" (10.3 x 38.1mm).

**Construction:** Melamine tube.

### Ratings:

- Volts — 600Vac (or less)
- 300Vdc (1/2-2%<sub>0</sub>A & 20-30A)
- 150Vdc (3-15A)
- Amps — 1/2-30A
- IR — 200,000A RMS Sym.
- 20,000A dc



**Agency Information:** CE, Std. 248-4, Class CC, UL Listed, Guide JDDZ, File E4273, CSA Certified; Class 1422-02, File 53787.

### Features and Benefits

- Time delay coupled with Class CC current-limiting response provides close sizing on small motor and relay circuits, and maximum component short-circuit current rating protection.
- 200,000A interrupting rating provides high ratings for control circuit locations.
- Class CC rejection feature, with appropriate fuse block, prevents inserting lesser-rated supplementary fuses.
- Inventory consolidation of 1 1/2 x 1 1/2 inch supplementary fuses reduces SKU investment and minimizes potential for misapplying fuse.

### Typical Applications

- Specialized Circuits
- Industrial Control
- Isolated, In-Line Fuse Holder

### Catalog Numbers (Amps)

LP-CC-1/2	LP-CC-2 1/2	LP-CC-7 1/2
LP-CC-3/10	LP-CC-2 3/10	LP-CC-8
LP-CC-3/10	LP-CC-3	LP-CC-9
LP-CC-1	LP-CC-3 3/10	LP-CC-10
LP-CC-1 1/8	LP-CC-3 1/2	LP-CC-12
LP-CC-1 1/4	LP-CC-4	LP-CC-15
LP-CC-1 3/10	LP-CC-4 1/2	LP-CC-20
LP-CC-1 1/2	LP-CC-5	LP-CC-25
LP-CC-1 5/10	LP-CC-5 3/10	LP-CC-30
LP-CC-1 7/10	LP-CC-6	
LP-CC-2	LP-CC-6 1/4	
LP-CC-2 1/4	LP-CC-7	

### Time Current Characteristics—Average Melt

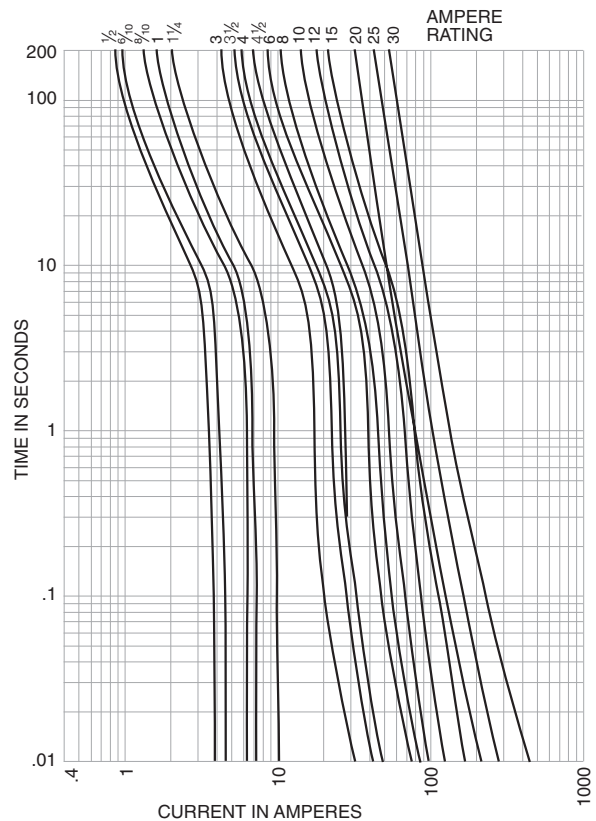

### Current Limitation Curves

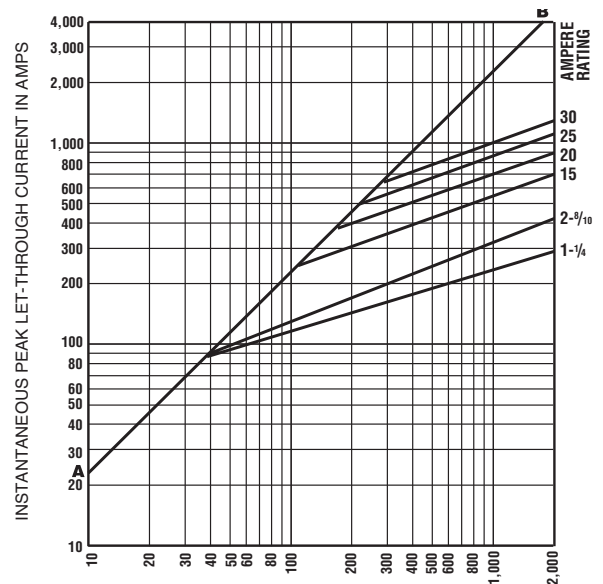

PROSPECTIVE SHORT-CIRCUIT CURRENT—SYMMETRICAL RMS AMPS

### Recommended Fuse Holders & Blocks For Class CC 600V Fuses

- See page 8

Data Sheet: 1023 (0-30)

**Low-Peak® time-delay fuses**

**KRP-C\_SP Class L**

**Specifications**

**Description:** Time-delay fuse – 4 seconds (minimum) at 500% rated amps.

**Dimensions:** See page 12 for Class L dimensions.

**Construction:** Glass melamine tube with silver-plated end bells and blades. High grade silica-sand filler to quench fuse arc. O-ring seals to maximize pressure build-up during current-limiting action and ensure filler retention.

**Ratings:**

- Volts — 600Vac (or less)
- 300Vdc (601-2000A)
- Amps — 601-6000A
- (use KRP-CL for current ratings under 601A)
- IR — 300,000A RMS Sym.
- 100,000A dc

**Agency Information:** CE, UL Listed-Special Purpose (meets all performance requirements of UL Standard 248-10 for Class L fuses), Guide JFHR, File E56412, CSA Certified (200,000 AIR), Class 1422-02, File 53787, Class L per CSA C22.2, No. 248.10.

**Features and Benefits**

- Time delay of four seconds at five times rating allows closer sizing on large motor loads combined with Class L current limitation.
- Selective coordination ratio of 2:1 (within Low-Peak fuse family) prevents electrical shutdowns from extending beyond the failed circuit.
- Interrupting rating of 300,000A RMS symmetrical provides adequate ratings without obsolescence for all electrical systems, big or small.
- Quality construction, using high-grade materials, provides lower watts loss and operating temperatures with superior arc quenching during current-limiting action.

**Typical Applications**

- Large Distribution Switchboards
- Power Panelboards
- Large Machinery Disconnects

**Catalog Numbers (Amps)**

KRP-C-601SP	KRP-C-1000SP	KRP-C-1800SP	KRP-C-3500SP
KRP-C-650SP	KRP-C-1100SP	KRP-C-1900SP	KRP-C-3800SP
KRP-C-700SP	KRP-C-1200SP	KRP-C-2000SP	KRP-C-4000SP
KRP-C-750SP	KRP-C-1350SP	KRP-C-2001SP	KRP-C-4500SP
KRP-C-800SP	KRP-C-1400SP	KRP-C-2400SP	KRP-C-5000SP
KRP-C-801SP	KRP-C-1500SP	KRP-C-2500SP	KRP-C-6000SP
KRP-C-900SP	KRP-C-1600SP	KRP-C-3000SP	



Did You Know?

SKU Reduction Through Productivity Protector™ Program

An industrial manufacturing plant in Springfield, Missouri, found that SKUs in its spare fuse inventory were becoming excessive and the plant could not possibly keep a spare for each different fuse type.

The Cooper Bussmann® district sales engineer applied the new Productivity Protector program, conducting a cross-reference analysis of all fuse SKUs at the facility and producing an upgrade report to identify the recommended Cooper Bussmann® Low-Peak® fuses to reduce the plant's inventory. Because more than 47 different types of fuses can be replaced by Low-Peak fuses, the plant was able to reduce its fuse inventory by 25%, resulting in substantial cost savings. The plant also immediately noted it experienced less downtime, crediting the highest degree of current limitation provided by Low-Peak fuse. The sales engineer also provided plant personnel with product application support and safety training.

**Recommended Fuse Holders & Blocks For Class L 600V Fuses**

- See page 9

**Data Sheets: 1008 and 1009**

# Low Voltage, Branch Circuit Rated Fuses

## Low-Peak® time-delay fuses

**Time-Current Characteristic Curves—Average Melt**

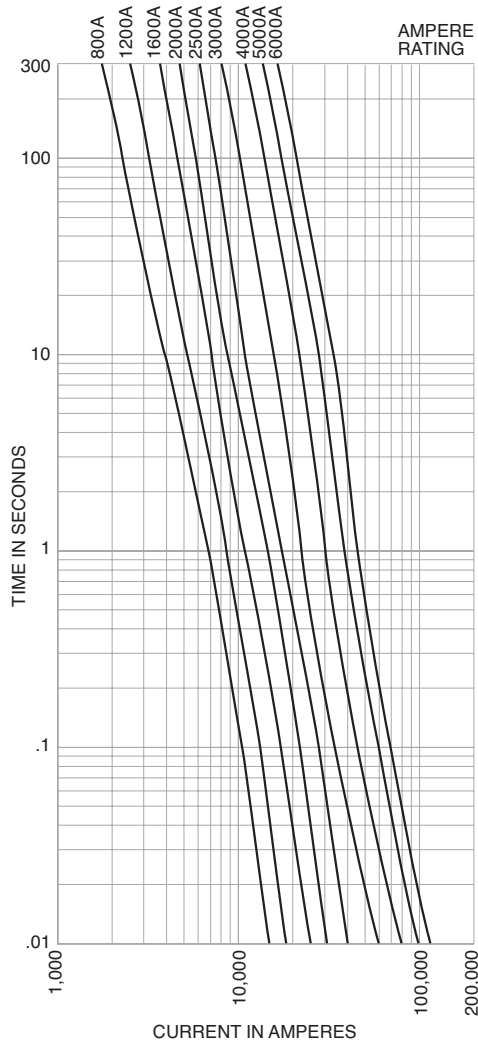

**Current Limitation Curves**

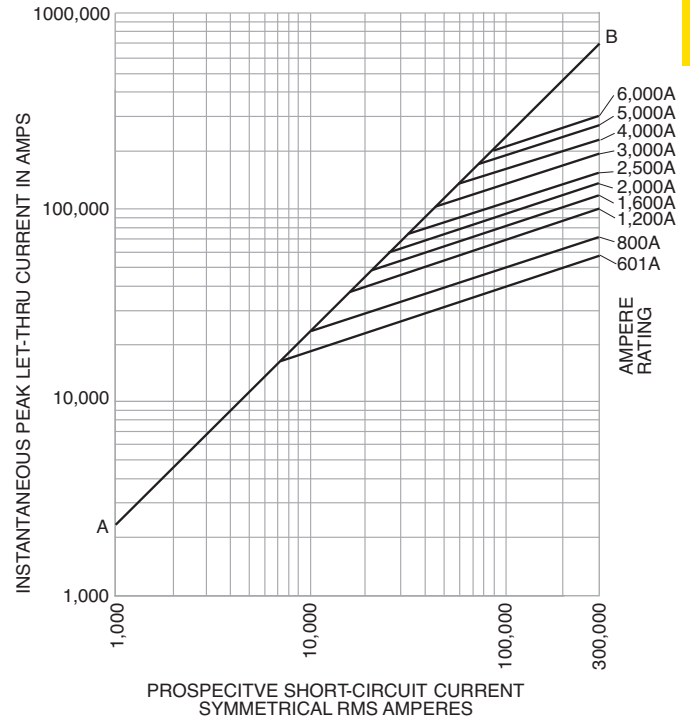

Low Voltage  
Branch  
Circuit  
Fuses

**Data Sheets: 1008 and 1009**

### KRP-CL Current-limiting, time-delay fuses

**Specifications**

**Description:** Current-limiting, time-delay fuse.

**Dimensions:** See page 12 for Class L dimensional data.

**Construction:** Glass melamine tube.

**Ratings:**

Volts — 600Vac (or less)

Amps — 150-600A

IR — 200,000A RMS Sym.

**Features and Benefits**

- Time delay of four seconds at five times rating allows closer sizing inductive loads coupled with an equivalent Class L current limitation.

- Class L case size for amp ratings from 150A to 600A allows downsize fusing of large Class L fused switches for improved circuit protection.

**Typical Applications**

- Large Distribution Switchboards
- Power Panelboards
- Machinery Disconnects

**Catalog Numbers (Amps)**

KRP-CL-150	KRP-CL-300	KRP-CL-500
KRP-CL-200	KRP-CL-350	KRP-CL-600
KRP-CL-225	KRP-CL-400	
KRP-CL-250	KRP-CL-450	

**Data Sheet: 1016**

**Recommended Fuse Holders & Blocks For Class L 600V Fuses**

- See page 9

# Fusetron® dual-element, time-delay fuses

## FRN-R (250V) Class RK5

### Specifications

**Description:** Dual-element, time-delay fuse – 10 seconds (minimum) at 500% rated amps.

**Dimensions:** See page 11 for Class RK5 dimensions.

**Construction:** Fiberglass tube.

### Ratings:

- Volts — 250Vac (or less)
- 125Vdc (1/10-200A)
- 250Vdc (201-600A)
- Amps — 1/10-600A
- IR — 200,000A RMS Sym.
- 20,000A dc

**Agency Information:** CE, Std. 248-12, Class RK5, UL Listed, Guide JDDZ, File E4273, CSA Certified, Class 1422-01, File 53787.

### Features and Benefits

- Separate overload and short-circuit elements provide time delay for 125% of motor FLA sizing, linked with RK5 current limitation.
- 2:1 selective coordination ratio (within the Cooper Bussmann® RK5 fuse family) prevents electrical shutdowns from extending beyond the failed circuit.
- Insulated end caps for 110A-600A fuses reduces exposure to live parts and extends air gap to distance between blades of adjacent mounted fuses or to housing.

### Typical Applications

- Power Panelboards
- Motor Control Centers
- Combination Starters
- Machinery Disconnects

### Catalog Numbers (Amps)

FRN-R-1/10	FRN-R-2	FRN-R-10	FRN-R-100
FRN-R-1/8	FRN-R-2 1/4	FRN-R-12	FRN-R-110
FRN-R-1/6	FRN-R-2 1/2	FRN-R-15	FRN-R-125
FRN-R-1/4	FRN-R-2 3/4	FRN-R-17 1/2	FRN-R-150
FRN-R-1/3	FRN-R-3	FRN-R-20	FRN-R-175
FRN-R-1/2	FRN-R-3 1/2	FRN-R-25	FRN-R-200
FRN-R-2/3	FRN-R-3 3/4	FRN-R-30	FRN-R-225
FRN-R-1/2	FRN-R-4	FRN-R-35	FRN-R-250
FRN-R-1/3	FRN-R-4 1/2	FRN-R-40	FRN-R-300
FRN-R-1/4	FRN-R-5	FRN-R-45	FRN-R-350
FRN-R-1	FRN-R-5 1/2	FRN-R-50	FRN-R-400
FRN-R-1 1/8	FRN-R-6	FRN-R-60	FRN-R-450
FRN-R-1 1/4	FRN-R-6 1/4	FRN-R-70	FRN-R-500
FRN-R-1 1/6	FRN-R-7	FRN-R-75	FRN-R-600
FRN-R-1 1/3	FRN-R-7 1/2	FRN-R-80	
FRN-R-1 1/2	FRN-R-8	FRN-R-85	
FRN-R-1 3/4	FRN-R-9	FRN-R-90	



### Current Limitation Curves

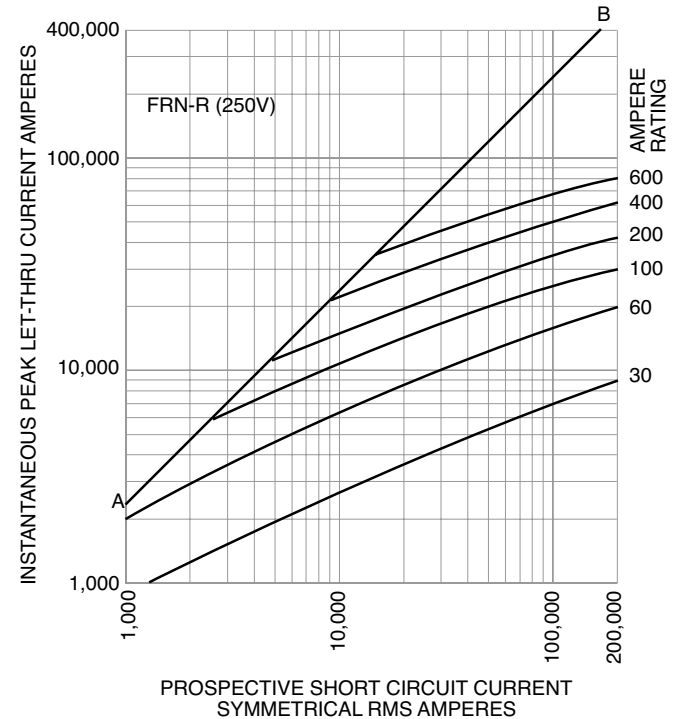

For superior electrical protection, Cooper Bussmann recommends upgrading FRN-R fuse applications to Low-Peak® LPN-RK fuses. See page 16.

### Recommended Fuse Holders & Blocks For Class RK5 250V Fuses

- See page 9

### Recommended Fuse Reducers For Class R Fuses

- See page 10

Data Sheets: 1019 (0-60) and 1020 (70-600)

Low Voltage, Branch Circuit Rated Fuses

Fusetron® dual-element, time-delay fuses

Time-Current Characteristic Curves—Average Melt

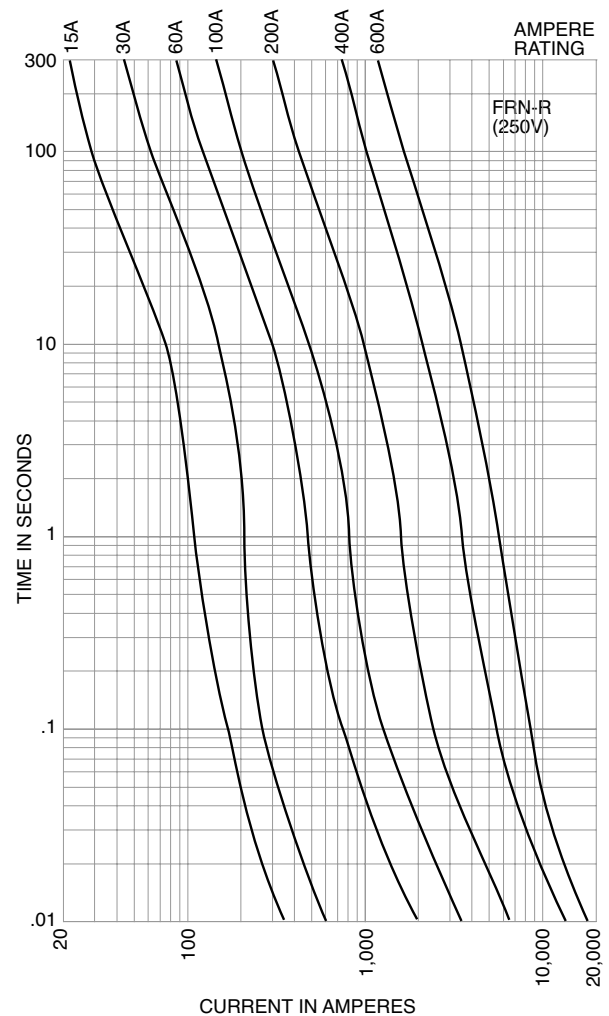
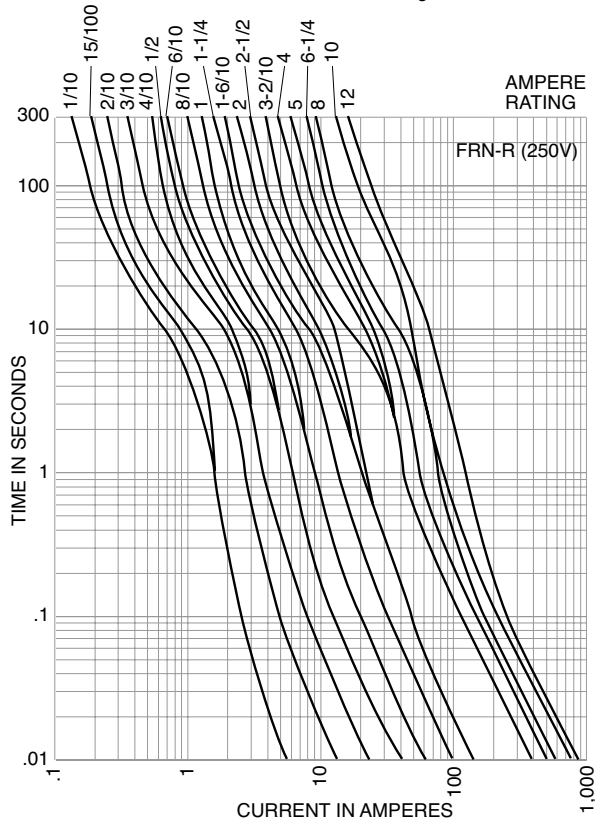

Low Voltage  
Branch  
Circuit  
Fuses

**Did You Know?**



Cooper Bussmann® fuses keep the lights on and the trams running to the top of the Jefferson National Expansion Memorial 630 foot high Gateway Arch.

For superior electrical protection, Cooper Bussmann recommends upgrading FRN-R fuse applications to Low-Peak LPN-RK fuses See page 16.

**Recommended Fuse Holders & Blocks For Class RK5 250V Fuses**

- See page 9

Data Sheets: 1019 (0-60) and 1020 (70-600)

# Fusetron® dual-element, time-delay fuses

## FRS-R (600V) Class RK5

### Specifications

**Description:** Dual-element, time-delay fuse – 10 seconds (minimum) at 500% rated amps.

**Dimensions:** See page 11 for Class RK5 dimensions.

**Construction:** Fiberglass tube.

### Ratings:

- Volts — 600Vac (or less)
- 300Vdc
- Amps — 1/10-600A
- IR — 200,000A RMS Sym.
- 20,000A @ 300Vdc

**Agency Information:** CE, Std. 248-12, Class RK5, UL Listed, Guide JDDZ, File E4273, CSA Certified, Class 1422-02, File 53787.

### Features and Benefits

- 2:1 selective coordination ratio (within RK5 fuse family) prevents electrical shutdowns from extending beyond the failed circuit.
- Insulated end caps for 70-600A fuses reduces exposure to live parts and extends air gap to distance between blades of adjacent mounted fuses or to housing.

### Typical Applications

- Power Panelboards
- Motor Control Centers
- Combination Starters
- Machinery Disconnects

### Catalog Numbers (Amps)

FRS-R-1/10	FRS-R-2	FRS-R-10	FRS-R-110
FRS-R-1/8	FRS-R-2 1/4	FRS-R-12	FRS-R-125
FRS-R-1/6	FRS-R-2 1/2	FRS-R-15	FRS-R-150
FRS-R-1/4	FRS-R-2 3/4	FRS-R-17 1/2	FRS-R-175
FRS-R-1/3	FRS-R-3	FRS-R-20	FRS-R-200
FRS-R-1/2	FRS-R-3 1/2	FRS-R-25	FRS-R-225
FRS-R-2/3	FRS-R-3 3/4	FRS-R-30	FRS-R-250
FRS-R-1/2	FRS-R-4	FRS-R-35	FRS-R-275
FRS-R-5/10	FRS-R-4 1/2	FRS-R-40	FRS-R-300
FRS-R-1/3	FRS-R-5	FRS-R-45	FRS-R-325
FRS-R-1	FRS-R-5 1/2	FRS-R-50	FRS-R-350
FRS-R-1 1/8	FRS-R-6	FRS-R-60	FRS-R-400
FRS-R-1 1/4	FRS-R-6 1/4	FRS-R-70	FRS-R-450
FRS-R-1 1/2	FRS-R-7	FRS-R-75	FRS-R-500
FRS-R-1 3/4	FRS-R-7 1/2	FRS-R-80	FRS-R-600
FRS-R-1 1/2	FRS-R-8	FRS-R-90	
FRS-R-1 1/2	FRS-R-9	FRS-R-100	

For superior electrical protection, Cooper Bussmann recommends upgrading FRS-R fuse applications to Low-Peak® LPS-RK fuses See page 16.

### Recommended Fuse Holders & Blocks For Class RK5

#### 600V Fuses

- See page 9

**Data Sheet: 1017 (0-60), 1018 (70-600)**

### Time-Current Characteristic Curves—Average Melt

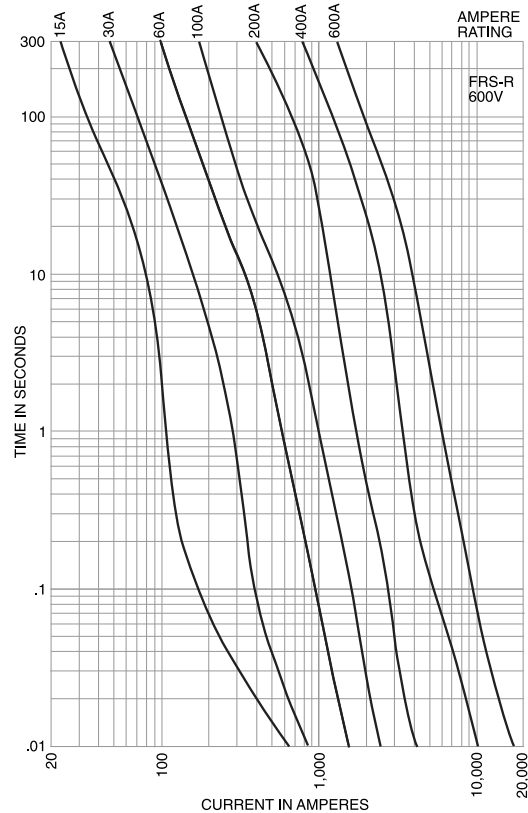

### Current Limitation Curves

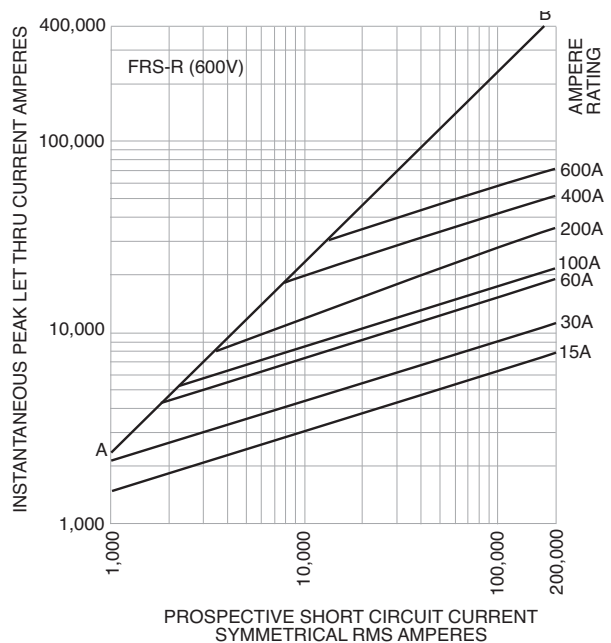

### Recommended Fuse Reducers For Class R Fuses

- See page 10

## Drive Fuse high speed fuses

Low Voltage Branch Circuit Fuses

### DFJ Class J



#### Specifications

**Description:** High speed, current-limiting fuse. The new Cooper Bussmann® Drive Fuse will provide maximum protection for AC and DC drives and controllers and meet NEC® branch circuit protection requirements. The Drive Fuse has the lowest I<sup>2</sup>t of any branch circuit fuse to protect power semiconductor devices that utilize diodes, GTOs, SCRs and SSRs.

**Dimensions:** See page 11 for Class J dimensions.

**Construction:** Melamine tube with silver fuse element.

#### Ratings:

Volts — 600Vac (or less), 450Vdc (or less)

Amps — 1-600A

IR — 200,000A RMS Sym., 100,000A dc

**Agency Information:** CE, Std. 248-8, Class J, UL Listed, Guide JDDZ, File E4273, CSA Certified, Class 1422-02, File 53787.

#### Features and Benefits

- Easily coordinated with existing and new variable speed drives and electric controllers.
- Standard Class J dimensions allowing the use of readily available fuse blocks, holders, and switches.
- Allows the lowest let-thru energy of any branch circuit overcurrent protective device.

#### Typical Applications

- Protection of ac & dc drives
- Equipment using power semi-conductor devices

#### Catalog Numbers (Amps)

DFJ-1	DFJ-15	DFJ-70	DFJ-225
DFJ-2	DFJ-20	DFJ-80	DFJ-250
DFJ-3	DFJ-25	DFJ-90	DFJ-300
DFJ-4	DFJ-30	DFJ-100	DFJ-350
DFJ-5	DFJ-35	DFJ-110	DFJ-400
DFJ-6	DFJ-40	DFJ-125	DFJ-450
DFJ-8	DFJ-45	DFJ-150	DFJ-500
DFJ-10	DFJ-50	DFJ-175	DFJ-600
DFJ-12	DFJ-60	DFJ-200	

### Time-Current Characteristic Curves—Average Melt

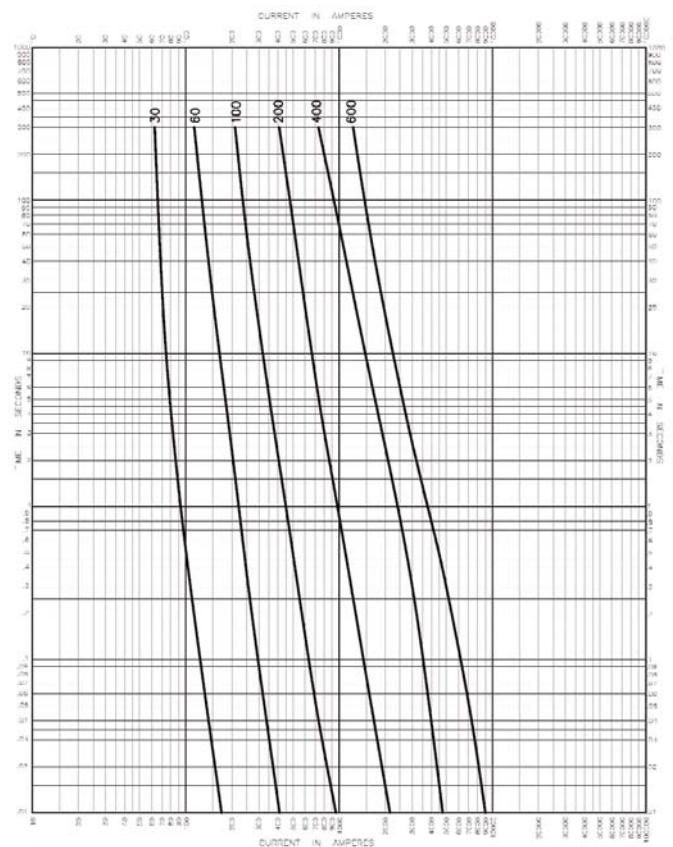

### Current Limitation Curves

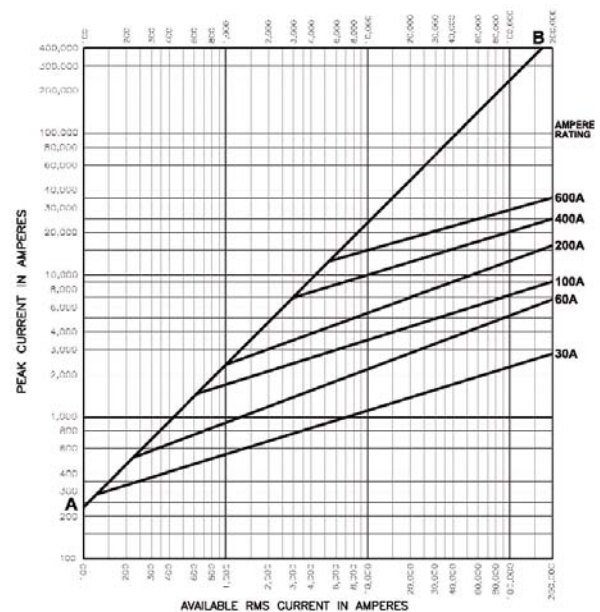

Data Sheet: 1049

## Low Voltage, Branch Circuit Rated Fuses

### Limitron® fast-acting fuses

#### JKS Class J



#### Specifications

**Description:** Fast-acting, current-limiting fuse.

**Dimensions:** See page 11 for Class J dimensions.

**Construction:** Melamine tube with silver fuse element.

#### Ratings:

Volts — 600Vac (or less)

Amps — 1-600A

IR — 200,000A RMS Sym.

**Agency Information:** CE, Std. 248-8, Class J, UL Listed, Guide JDDZ, File E4273, CSA Certified, Class 1422-02, File 53787.

#### Features and Benefits

- Current limitation for non-inductive circuits provides Class J current-limiting response to maximum ground fault and short-circuit conditions.
- 200,000A interrupting rating provides high ratings at all circuit locations.
- Economical solutions for high-fault circuits.

#### Typical Applications

- Power Panelboards
- Machinery Disconnects

#### Catalog Numbers (Amps)

JKS-1	JKS-15	JKS-70	JKS-225
JKS-2	JKS-20	JKS-80	JKS-250
JKS-3	JKS-25	JKS-90	JKS-300
JKS-4	JKS-30	JKS-100	JKS-350
JKS-5	JKS-35	JKS-110	JKS-400
JKS-6	JKS-40	JKS-125	JKS-450
JKS-8	JKS-45	JKS-150	JKS-500
JKS-10	JKS-50	JKS-175	JKS-600
JKS-12	JKS-60	JKS-200	

#### Fuse Reducers for J Dimension Fuses

Equipment Fuse Clip Amps	Desired Fuse (Case) Amp Size	Catalog No. (Pairs)
60	30	J63
100	30	J13
100	60	J16
200	60	J26
200	100	J21
400	100	J41
400	200	J42
600	200	J62
600	400	J64

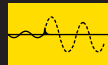

#### Did You Know?

#### Reduce Downtime with Cooper Bussmann® 24/7 Emergency After-Hours Service

When overloads or short circuits open the fuse and there are no spares on the shelf, where do you turn to get the production line back up, the trains running or the elevators operating?

Customers pay only standard price for the required circuit protection device, rush freight charges and a \$75.00 emergency fee for this door-to-door service. No minimum order requirements. No surcharges for drop shipments.

#### Call us at 314-995-1342 and we will:

Set the Cooper Bussmann Customer Satisfaction team in motion to do what it takes to satisfy your needs.

Next flight out or next day service; your choice.

For superior electrical protection, Cooper Bussmann recommends upgrading JKS fuse applications to Low-Peak LPJ fuses See page 15.

#### Recommended Fuse Holders & Blocks For Class J 600V Fuses

- See page 10

# Limitron® fast-acting fuses

Low Voltage  
Branch  
Circuit  
Fuses

## KTN-R (250V) Class RK1

### Specifications

**Description:** Fast-acting, current-limiting fuse.

**Dimensions:** See page 11 for Class RK1 dimensions.

**Construction:** Melamine tube with silver fuse element.

### Ratings:

Volts — 250Vac (or less)

Amps — 1-600A

IR — 200,000A RMS Sym.

**Agency Information:** CE, Std. 248-12, Class RK1, UL Listed, Guide JDDZ, File E54273, CSA Certified, Class 1422-02, File 53787.

### Features and Benefits

- Current limitation for non-inductive circuits provides Class RK1 current-limiting response to maximum ground fault and short-circuit conditions.
- 200,000A interrupting rating provides high ratings at all circuit locations.
- Economical solutions for high-fault circuits.

### Typical Applications

- Panelboards



Time-Current Characteristic Curves—Average Melt

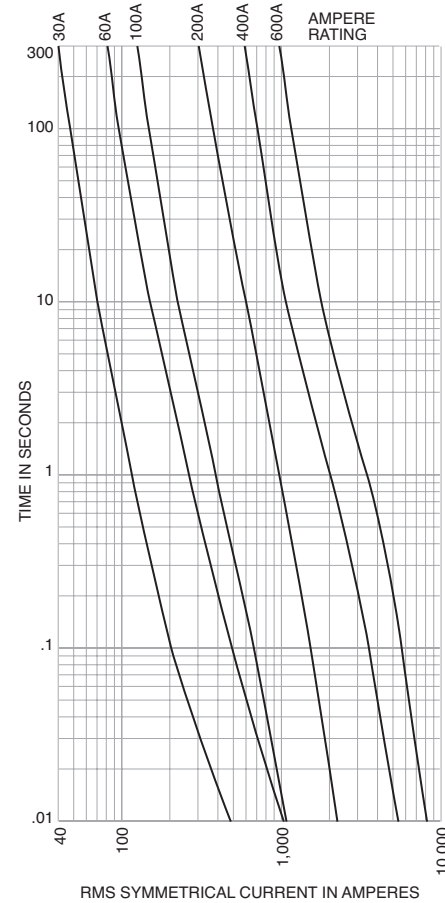

### Catalog Numbers (Amps)

KTN-R-1	KTN-R-30	KTN-R-125
KTN-R-2	KTN-R-35	KTN-R-150
KTN-R-3	KTN-R-40	KTN-R-175
KTN-R-4	KTN-R-45	KTN-R-200
KTN-R-5	KTN-R-50	KTN-R-225
KTN-R-6	KTN-R-60	KTN-R-250
KTN-R-8	KTN-R-70	KTN-R-300
KTN-R-10	KTN-R-75	KTN-R-350
KTN-R-12	KTN-R-80	KTN-R-400
KTN-R-15	KTN-R-90	KTN-R-450
KTN-R-20	KTN-R-100	KTN-R-500
KTN-R-25	KTN-R-110	KTN-R-600

For superior electrical protection, Cooper Bussmann recommends upgrading KTN-R fuse applications to Low-Peak LPN-RK fuses See page 16.

### Recommended Fuse Holders & Blocks For Class RK1 250V Fuses

- See page 9

Current Limitation Curves

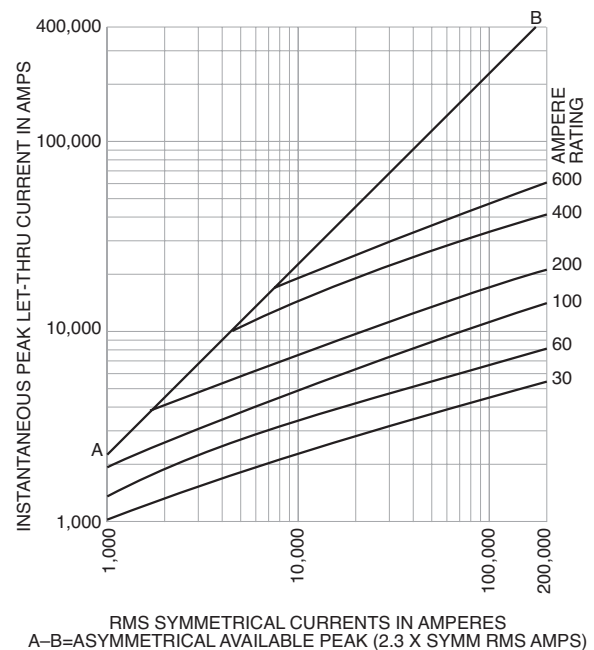

Data Sheet: 1043 (0-600)

# Limitron® fast-acting fuses

## KTS-R (600V) Class RK1

### Specifications

**Description:** Fast-acting, current-limiting fuse.

**Dimensions:** See page 11 for Class RK1 dimensions.

**Construction:** Melamine tube with silver fuse element.

### Ratings:

- Volts — 600Vac (or less)
- Amps — 1-600A
- IR — 200,000A RMS Sym.

**Agency Information:** CE, Std. 248-12, Class RK1, UL Listed, Guide JDDZ, File E54273, CSA Certified, Class 1422-02, File 53787.

### Features and Benefits

- Current limitation for non-inductive circuits provides Class RK1 current-limiting response to maximum ground fault and short-circuit conditions.
- 200,000A interrupting rating provides high ratings at all circuit locations.
- Economical solutions for high-fault circuits.

### Typical Applications

- Panelboards

### Catalog Numbers (Amps)

KTS-R-1	KTS-R-30	KTS-R-125
KTS-R-2	KTS-R-35	KTS-R-150
KTS-R-3	KTS-R-40	KTS-R-175
KTS-R-4	KTS-R-45	KTS-R-200
KTS-R-5	KTS-R-50	KTS-R-225
KTS-R-6	KTS-R-60	KTS-R-250
KTS-R-8	KTS-R-70	KTS-R-300
KTS-R-10	KTS-R-75	KTS-R-350
KTS-R-12	KTS-R-80	KTS-R-400
KTS-R-15	KTS-R-90	KTS-R-450
KTS-R-20	KTS-R-100	KTS-R-500
KTS-R-25	KTS-R-110	KTS-R-600



## Time-Current Characteristic Curves—Average Melt

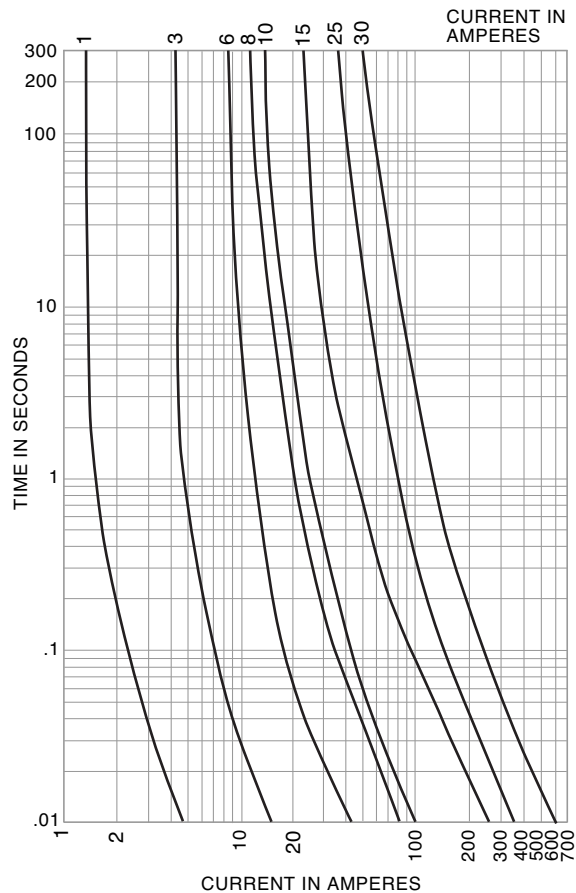

## Current Limitation Curves

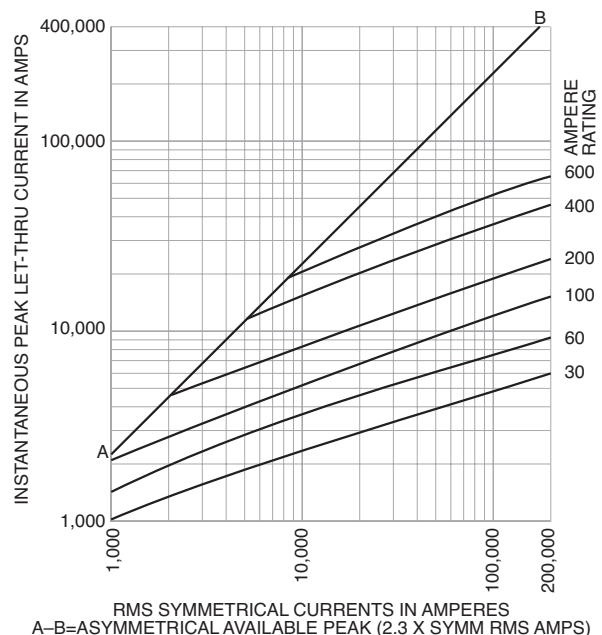

For superior electrical protection, Cooper Bussmann recommends upgrading KTS-R fuse applications to Low-Peak LPS-RK fuses See page 16.

### Recommended Fuse Holders & Blocks For Class RK1 600V Fuses

- See page 9

Data Sheet: 1044 (0-600)

# Limitron® rejection-type fuses

Low Voltage  
Branch  
Circuit  
Fuses

## KTK-R Class CC

### Specifications

**Description:** Fast-acting, branch circuit, rejection-type fuse.

**Dimensions:** 1 3/8" x 1 1/2" (10.3 x 38.1mm).

**Construction:** Melamine tube.

### Ratings:

Volts — 600Vac (or less)

Amps — 1/10-30A

IR — 200,000A RMS Sym.

**Agency Information:** CE, Std. 248-4, Class CC, UL Listed, Guide JDDZ, File E4273 CSA Certified, File 53787, Class 1422-02.

### Features and Benefits

- Current limitation at Class CC levels provides maximum component short-circuit current rating protection.
- 200,000A interrupting rating provides high ratings for control circuit locations.
- Class CC rejection feature, with appropriate fuse block, prevents inserting lesser-rated supplementary fuses.

### Typical Applications

- Specialized Circuits
- Industrial Control
- Isolated, In-Line Fuse Holders (street lighting)

### Catalog Numbers (Amps)

KTK-R-1/10	KTK-R-1	KTK-R-7
KTK-R-1/8	KTK-R-1 1/2	KTK-R-8
KTK-R-3/10	KTK-R-2	KTK-R-9
KTK-R-1/4	KTK-R-2 1/2	KTK-R-10
KTK-R-3/10	KTK-R-3	KTK-R-12
KTK-R-1/10	KTK-R-3 1/2	KTK-R-15
KTK-R-1/2	KTK-R-4	KTK-R-20
KTK-R-5/10	KTK-R-5	KTK-R-25
KTK-R-3/4	KTK-R-6	KTK-R-30



Time-Current Characteristic Curves—Average Melt

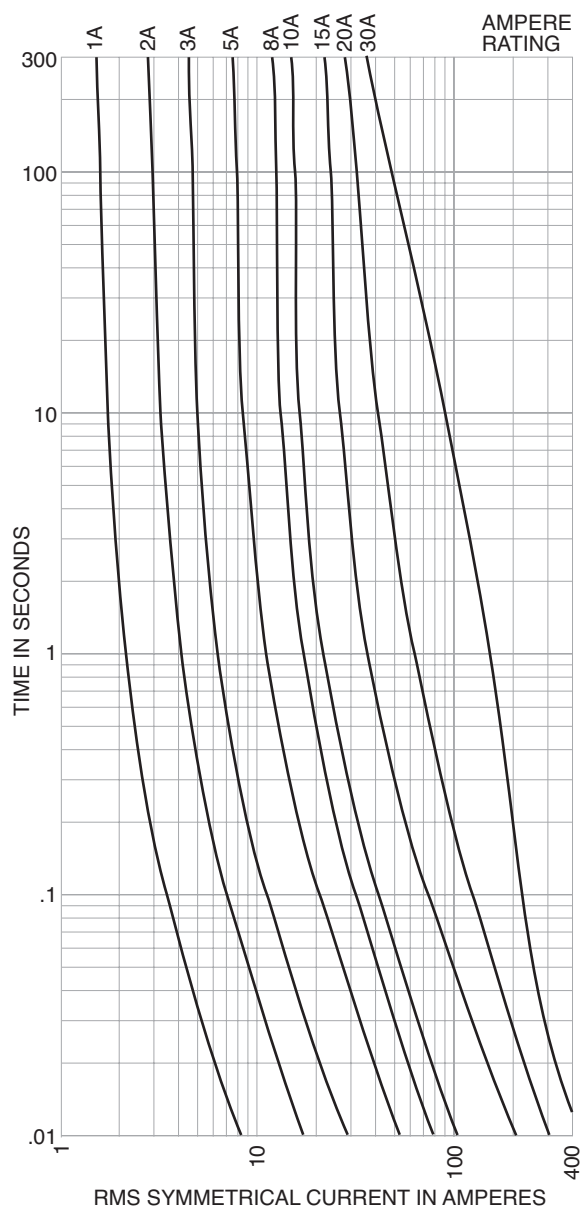

For superior electrical protection, Cooper Bussmann recommends upgrading KTK-R fuse applications to Low-Peak LP-CC fuses See page 19.

### Recommended Fuse Holders & Blocks For Class CC 600V Fuses

- See page 8

## Limitron® fuses

### KTU Class L

**Specifications**

**Description:** Fast-acting, bolt-mount fuse.

**Dimensions:** See page 12 for Class L dimensions.

**Construction:**

**Ratings:**

- Volts — 600Vac (or less)
- Amps — 601-6000A
- IR — 200,000A RMS Sym.

**Agency Information:** CE, Std. 248-10, Class L, UL Listed, Guide JDDZ, File E4273 CSA Certified, Class 1422-02, File 53787.

**Features and Benefits**

- 200,000A interrupting rating provides high ratings at all circuit locations.
- Economical solutions for high-fault circuits.
- Quality construction using high-grade materials provides lower watts loss and operating temperatures with superior arc quenching during current-limiting action.

**Typical Applications**

- Large Distribution Switchboards
- Power Panelboards

**Catalog Number (Amps)**

KTU-601	KTU-1200	KTU-2500
KTU-650	KTU-1350	KTU-3000
KTU-700	KTU-1400	KTU-3001
KTU-750	KTU-1500	KTU-4000
KTU-800	KTU-1600	KTU-4500
KTU-801	KTU-1800	KTU-5000
KTU-900	KTU-2000	KTU-6000
KTU-1100	KTU-2400	



### KLU Class L

**Specifications**

**Description:** Time-delay, bolt-mount fuse - 5 seconds (minimum) at 500% rated amps. See KRP-CL for amp ratings below 601A.

**Dimensions:** See page 12 for Class L dimensions.

**Construction:**

**Ratings:**

- Volts — 600Vac (or less)
- Amps — 601-4000A
- IR — 200,000A RMS Sym.

**Agency Information:** CE, Std. 248-10, Class L, UL Listed, Guide JDDZ, File E4273, CSA Certified, CSA Class 1422-02, File 53787.

**Features and Benefits**

- 200,000A interrupting rating provides high ratings at all circuit locations.
- Economical solutions for high fault circuits.

**Typical Applications**

- Large Distribution Switchboards
- Power Panelboards
- Large Machinery Disconnects

**Catalog Numbers (Amps)**

KLU-601	KLU-1200	KLU-2500
KLU-650	KLU-1500	KLU-3000
KLU-700	KLU-1600	KLU-4000
KLU-800	KLU-1800	
KLU-1000	KLU-2000	



For superior electrical protection, Cooper Bussmann recommends upgrading KTU fuse applications to Low-Peak KRP-C fuses See page 20.

**Recommended Fuse Holders & Blocks For Class L 600V Fuses**

- See page 9

For superior electrical protection, Cooper Bussmann recommends upgrading KLU fuse applications to Low-Peak KRP-C fuses See page 20.

**Recommended Fuse Holders & Blocks For Class L 600V Fuses**

- See page 9

## Dura-Lag™ dual-element, time-delay fuses

Low Voltage  
Branch  
Circuit  
Fuses

### DLN-R (250V) Class RK5

#### Specifications

**Description:** Dual-element, time-delay fuse – 10 seconds (minimum) at 500% rated amps.

**Dimensions:** See page 11 for Class RK5 dimensions.

**Construction:** Fiberglass tube.

#### Ratings:

Volts — 250Vac (or less)

Amps — 1-600A

IR — 200,000A RMS Sym.

**Agency Information:** CE, Std. 248-12, Class RK5, UL Listed, Guide JDDZ, File E4273, CSA Certified, Class 1422-02 File 53787.

#### Features and Benefits

- Separate overload and short-circuit elements provide time delay for close inductive load sizing, linked with RK5 current limitation.
- 200,000A interrupting rating provides high ratings at all circuit locations.

#### Typical Applications

- Power Panelboards
- Machinery Disconnects

#### Catalog Numbers (Amps)

DLN-R-1	DLN-R-15	DLN-R-100
DLN-R-2	DLN-R-20	DLN-R-125
DLN-R-2 ½	DLN-R-25	DLN-R-150
DLN-R-3	DLN-R-30	DLN-R-175
DLN-R-3 ¾	DLN-R-35	DLN-R-200
DLN-R-4	DLN-R-40	DLN-R-225
DLN-R-5	DLN-R-45	DLN-R-250
DLN-R-6	DLN-R-50	DLN-R-300
DLN-R-6 ¾	DLN-R-60	DLN-R-400
DLN-R-8	DLN-R-70	DLN-R-600
DLN-R-10	DLN-R-80	
DLN-R-12	DLN-R-90	

For superior electrical protection, Cooper Bussmann recommends upgrading DLN-R fuse applications to Low-Peak LPN-RK fuses See page 16.

#### Recommended Fuse Holders & Blocks For Class RK5

##### 250V Fuses

- See page 9

Data Sheet: 1021 (0-600)

### DLS-R (600V) Class RK5

#### Specifications

**Description:** Dual-element, time-delay fuse – 10 seconds (minimum) at 500% rated amps.

**Dimensions:** See page 11 for Class RK5 dimensions.

**Construction:** Fiberglass tube.

#### Ratings:

Volts — 600Vac (or less)

Amps — 1-600A

IR — 200,000A RMS Sym.

**Agency Information:** CE, Std. 248-12, Class RK5, UL Listed, Guide JDDZ, File E4273, CSA Certified, Class 1422-02 File 53787.

#### Features and Benefits

- Separate overload and short-circuit elements provide time delay for close inductive load sizing, linked with RK5 current limitation.
- 200,000A interrupting rating provides high ratings at all circuit locations.

#### Typical Applications

- Power Panelboards
- Machinery Disconnects

#### Catalog Numbers (Amps)

DLS-R-1	DLS-R-12	DLS-R-100
DLS-R-1 ¾	DLS-R-15	DLS-R-110
DLS-R-2	DLS-R-17 ½	DLS-R-125
DLS-R-2 ½	DLS-R-20	DLS-R-150
DLS-R-3	DLS-R-25	DLS-R-175
DLS-R-3 ¾	DLS-R-30	DLS-R-200
DLS-R-4	DLS-R-35	DLS-R-225
DLS-R-5	DLS-R-40	DLS-R-250
DLS-R-6	DLS-R-45	DLS-R-300
DLS-R-6 ¾	DLS-R-50	DLS-R-350
DLS-R-7	DLS-R-60	DLS-R-400
DLS-R-8	DLS-R-70	DLS-R-500
DLS-R-9	DLS-R-80	DLS-R-600
DLS-R-10	DLS-R-90	

For superior electrical protection, Cooper Bussmann recommends upgrading DLS-R fuse applications to Low-Peak LPS-RK fuses See page 16.

#### Recommended Fuse Holders & Blocks For Class RK5

##### 600V Fuses

- See page 9

Data Sheet: 1022 (0-600)

# CC-Tron® rejection-type fuses

## FNQ-R Class CC

### Specifications

**Description:** Time-delay, branch circuit, rejection-type fuse.

**Dimensions:** 1<sup>3</sup>/<sub>32</sub>" x 1 1/2" (10.3 x 38.1mm).

**Construction:** Melamine tube.

### Ratings:

- Volts — 600Vac (or less)
- Amps — 1/4-30A
- IR — 200,000A RMS Sym.

**Agency Information:** CE, Std. 248-4, Class CC, UL Listed, Guide JDDZ, File E4273 CSA Certified, Class 1422-01, File 53787.

### Features and Benefits

- Time delay compatible with inrush characteristic of small control transformers.
- Current limitation at Class CC levels provides maximum component short-circuit current rating protection.
- 200,000A interrupting rating provides high ratings for control circuit locations.
- Class CC rejection feature, with appropriate fuse block, prevents inserting lesser-rated supplementary fuses.

### Typical Applications

- Specialized Circuits
- Industrial Control
- Isolated, In-Line Fuse Holders
- Line Protection, Small Control Transformers

### Catalog Numbers (Amps)

FNQ-R-1/4	FNQ-R-1 1/10	FNQ-R-7
FNQ-R-3/10	FNQ-R-1 1/5	FNQ-R-7 1/2
FNQ-R-1/2	FNQ-R-2	FNQ-R-8
FNQ-R-5/10	FNQ-R-2 1/4	FNQ-R-9
FNQ-R-3/4	FNQ-R-2 1/2	FNQ-R-10
FNQ-R-9/10	FNQ-R-2 2/5	FNQ-R-12
FNQ-R-1	FNQ-R-3	FNQ-R-15
FNQ-R-1 1/5	FNQ-R-3 3/10	FNQ-R-17 1/2
FNQ-R-1 1/4	FNQ-R-3 1/2	FNQ-R-20
FNQ-R-1 1/3	FNQ-R-4	FNQ-R-25
FNQ-R-1 2/5	FNQ-R-5	FNQ-R-30
FNQ-R-1 1/2	FNQ-R-6	
FNQ-R-1 1/2	FNQ-R-6 1/4	



## Time-Current Characteristic Curves—Average Melt

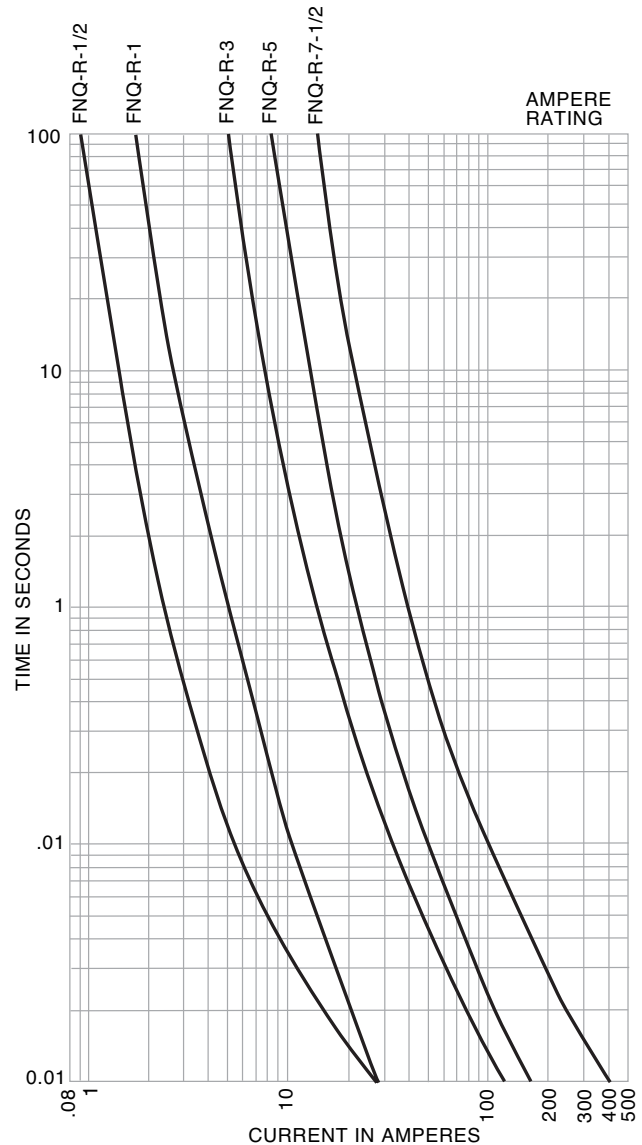

For superior electrical protection, Cooper Bussmann recommends upgrading FNQ-R fuse applications to Low-Peak LP-CC fuses See page 19.

### Recommended Fuse Holders & Blocks For Class CC 600V Fuses

- See page 8

# T-Tron® fast-acting fuses

Low Voltage  
Branch  
Circuit  
Fuses

## JJN Class T

### Specifications

**Description:** Very fast-acting, current-limiting fuse.

**Dimensions:** See page 12 for Class T dimensions.

**Construction:** Melamine tube with silver fuse element.



### Ratings:

- Volts — 300Vac (or less)
- 160Vdc (15-600A)
- 170Vdc (601-1200A)
- Amps — 1-1200A
- IR — 200,000 RMS Sym.
- 20,000A dc @ 160Vdc
- 100,000A dc @ 170Vdc

**Agency Information:** CE, Std. 248-15, Class T, UL Listed, Guide JDDZ, File E4273, CSA Certified, Class 1422-02, File 53787.

### Features and Benefits

- Series combination ratings with branch circuit breakers allows broad range of coverage, independent of breaker manufacturer.
- Current limitation for non-inductive circuits provides Class T current-limiting response to maximum ground fault and short-circuit conditions.
- 200,000A interrupting rating provides high ratings at all circuit locations.
- Small footprint allows more efficient use of available space.

### Typical Applications

- Large Apartment Complexes
- Multi-Family Meter Stacks
- VFD Line Protection

### Catalog Numbers (Amps)

JJN-1	JJN-15	JJN-40	JJN-80	JJN-150	JJN-300	JJN-600
JJN-2	JJN-20	JJN-45	JJN-90	JJN-175	JJN-350	JJN-700
JJN-3	JJN-25	JJN-50	JJN-100	JJN-200	JJN-400	JJN-800
JJN-6	JJN-30	JJN-60	JJN-110	JJN-225	JJN-450	JJN-1000
JJN-10	JJN-35	JJN-70	JJN-125	JJN-250	JJN-500	JJN-1200

Data Sheet: 1025

### Recommended Fuse Holders & Blocks For Class T 300V Fuses

- See page 9

### Time-Current Characteristic Curves—Average Melt

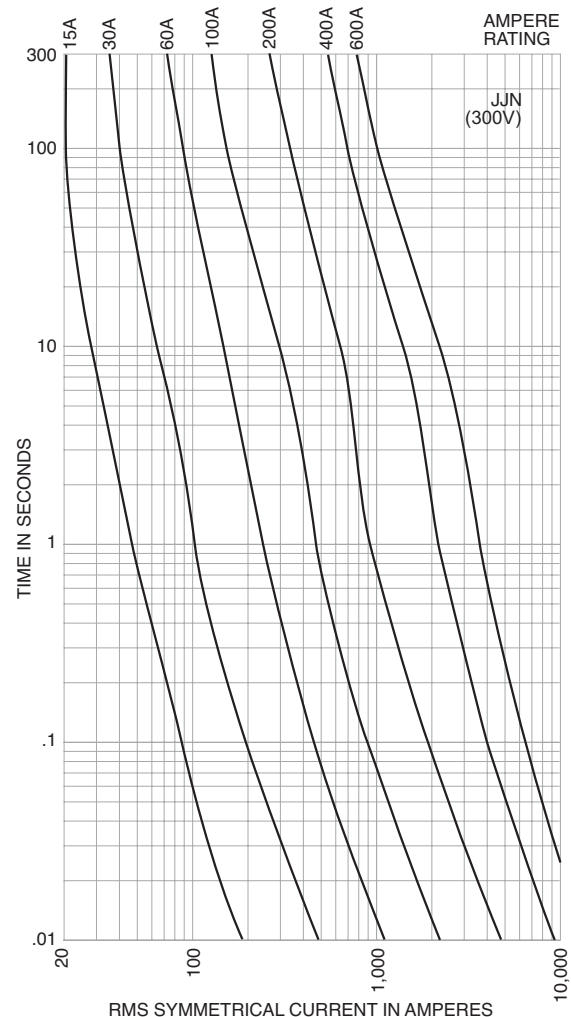

### Current Limitation Curves

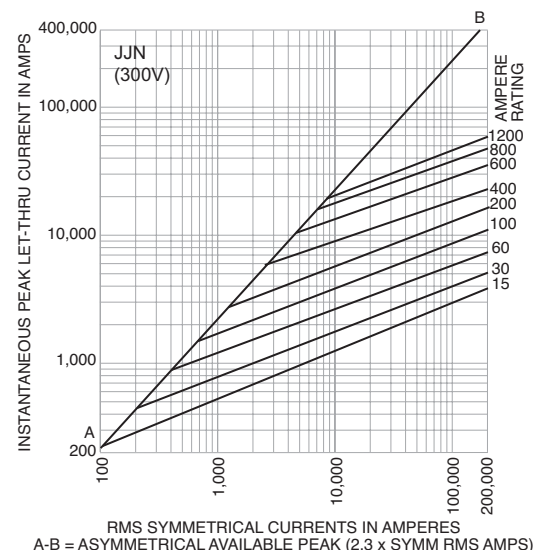

# T-Tron® fast-acting fuses

## JJS Class T

### Specifications

**Description:** Very fast-acting, current-limiting fuse.

**Dimensions:** See page 12 for Class T dimensions.

**Construction:** Melamine tube with silver fuse element.

### Ratings:

- Volts — 600Vac (or less)
- Amps — 1-800A
- IR — 200,000A RMS Sym.

**Agency Information:** CE, Std. 248-15, Class T, UL Listed, Guide JDDZ, File E4273, CSA Certified, Class 1422-02, File 53787.

### Features and Benefits

- Series combination ratings with branch circuit breakers allows broad range of coverage, independent of breaker manufacturer.
- Current limitation for non-inductive circuits provides Class T current-limiting response to maximum ground fault and short-circuit conditions.
- 200,000A interrupting rating provides high ratings at all circuit locations.
- Small footprint allows more efficient use of available space.

### Typical Applications

- Large Apartment Complexes
- Multi-Family Meter Stacks
- VFD Line Protection

### Catalog Numbers (Amps)

JJS-1	JJS-15	JJS-40	JJS-80	JJS-150	JJS-300	JJS-600
JJS-2	JJS-20	JJS-45	JJS-90	JJS-175	JJS-350	JJS-800
JJS-3	JJS-25	JJS-50	JJS-100	JJS-200	JJS-400	
JJS-6	JJS-30	JJS-60	JJS-110	JJS-225	JJS-450	
JJS-10	JJS-35	JJS-70	JJS-125	JJS-250	JJS-500	



## Time-Current Characteristic Curves—Average Melt

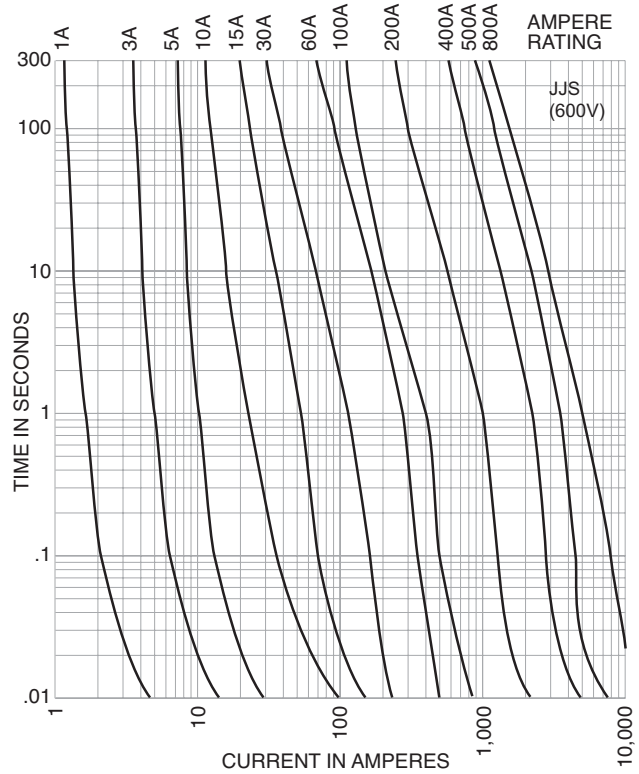

## Current Limitation Curves

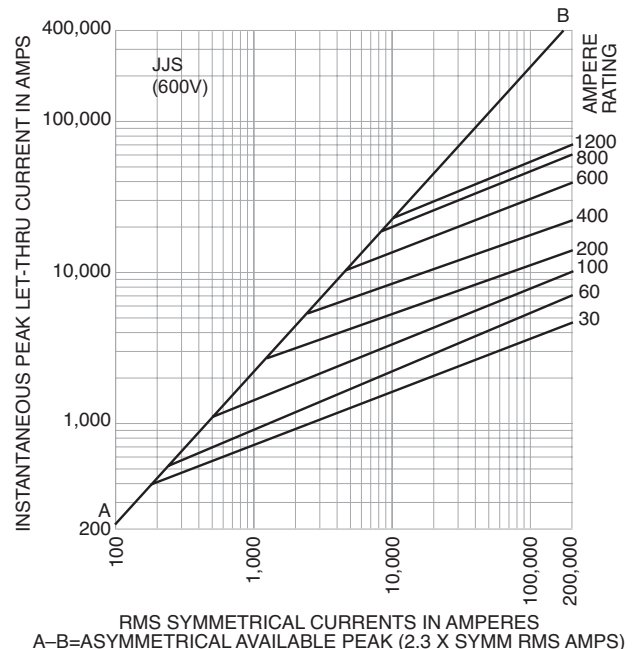

Data Sheet: 1029

### Recommended Fuse Holders & Blocks For Class T

#### 600V Fuses

- See page 9

# Time-delay fuses

Low Voltage  
Branch  
Circuit  
Fuses

## SC Class G

### Specifications

**Description:** Fast-acting (½-6A), time-delay (7-60A) fuse.

**Dimensions:** See Dimensions illustration.

**Construction:** Melamine tube.

### Ratings:

- Volts — 600Vac (½-20A)
- 480Vac (25-60A)
- 170Vdc (½-20A)
- 300Vdc (30 & 60A only)
- Amps — ½-60A
- IR — 100,000A RMS Sym.
- 10,000A dc



**Agency Information:** CE, Std. 248-5, Class G, UL Listed, Guide JDDZ, File E4273, CSA Certified, Class 1422-01, File 53787.

### Features and Benefits

- Current limiting for component protection, providing Class G energy-limitation for branch circuit protection.
- 100,000A interrupting rating provides cost-effective branch circuit fusing.
- Variations in length help prevent overfusing.

### Typical Applications

- Fusible Branch Panelboards
- HVAC Branch Circuit Protection

### Catalog Numbers (Amps)

SC-½	SC-2 ½	SC-6	SC-10	SC-25	SC-45
SC-1	SC-3	SC-7	SC-12	SC-30	SC-50
SC-1 ½	SC-4	SC-8	SC-15	SC-35	SC-60
SC-2	SC-5	SC-9	SC-20	SC-40	

### Dimensions -in (mm)

Fuse Amps	Length	Diameter
SC-½ to -15	1.31 (33.3)	0.41" (10.4)
SC-20	1.41 (35.8)	0.41" (10.4)
SC-25 to -30	1.62 (41.2)	0.41" (10.4)
SC-35 to -60	2.25 (57.1)	0.41" (10.4)

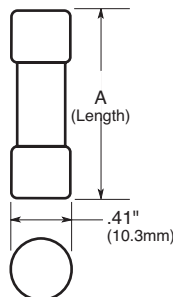

### Time-Current Characteristic Curves—Average Melt

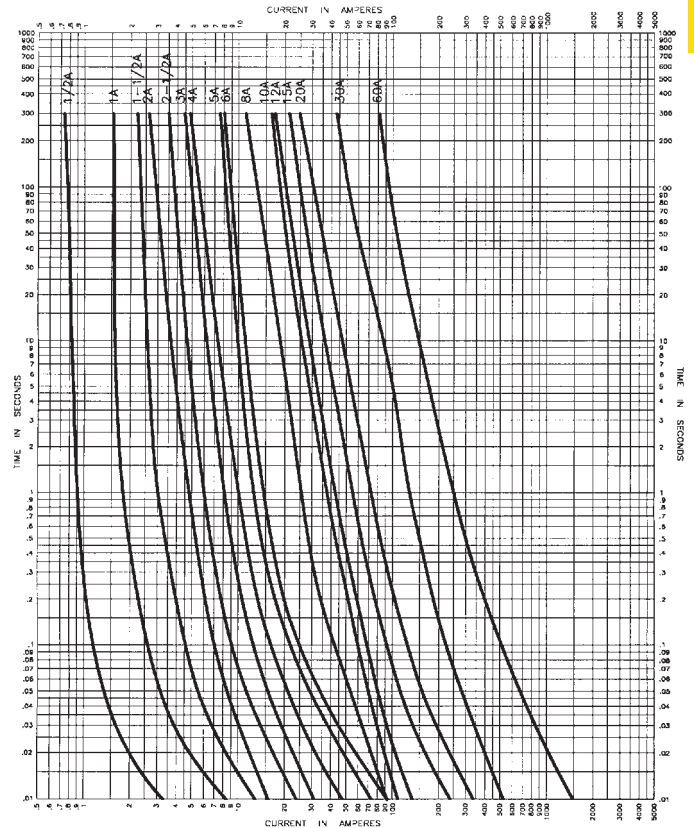

### Current Limitation Curves

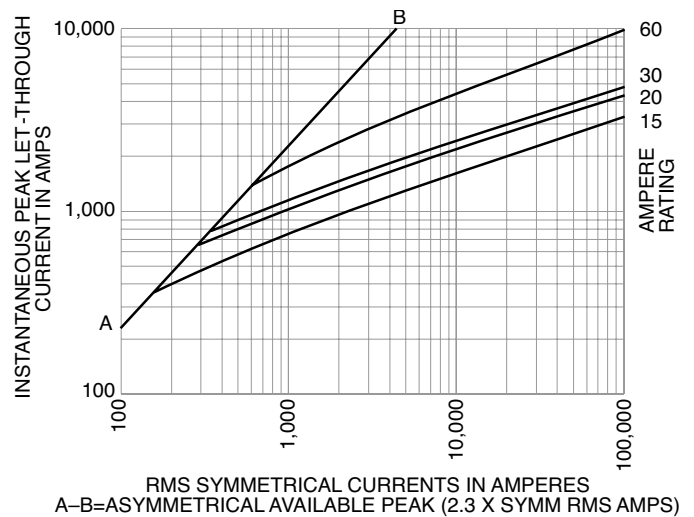

Data Sheet: 1024 (0-60)

**Recommended Fuse Holders & Blocks For Class G Fuses**  
• See page 8

## One-time general purpose fuses

### NON (250Vac/125Vdc) Class K5 & H

### NOS (600Vac) Class K5 & H

#### Specifications

**Description:** General purpose, non-current-limiting fuses.

**Dimensions:** See page 11 for dimensions.

#### Ratings:

Volts — **NON:**

- 250Vac
- 125Vdc (0-100A)

— **NOS:**

- 600Vac

Amps — 1/6-600A

IR — 50,000A RMS Sym. (NON & NOS Class K5 0-60A)

- 10,000A RMS Sym. (NON & NOS Class H 65-600A)

— 50,000A @ 125Vdc (NON Class K5 0-60A)

— 10,000A @ 125Vdc (NON Class H 65-100A)

**Agency Information:** CE, UL Listed – 250V: Class K5 (0-60A), Std. 248-9, Class H (65-600A), Std. 248-6, (125Vdc: NON 0-100), 600V: Class K5 (0-60A), Std. 248-9, Class H (70-600A), Std. 248-6, Guide JDDZ, File E4273, CSA Certified – 250V: (0-12, 65-600)†, 600V: (0-600), Class 1421-01, File 53787.

† For CSA Certified 15-60A Ratings, see PON Data Sheet 4126

#### Features and Benefits

- Original fuse providing circuit protection.

#### Typical Applications

- Light Duty Circuit Locations



### NOS (600Vac) Catalog Numbers (-Amps)

NOS-1	NOS-12	NOS-70	NOS-200
NOS-2	NOS-15	NOS-75	NOS-225
NOS-3	NOS-20	NOS-80	NOS-250
NOS-4	NOS-25	NOS-90	NOS-300
NOS-5	NOS-30	NOS-100	NOS-350
NOS-6	NOS-35	NOS-110	NOS-400
NOS-7	NOS-40	NOS-125	NOS-450
NOS-8	NOS-45	NOS-150	NOS-500
NOS-9	NOS-50	NOS-175	NOS-600
NOS-10	NOS-60		

### Recommended Fuse Reducers

250V Fuse Amp Size	Clip Amp Size	Catalog Number (Pair)	600V Fuse Amp Size	Clip Amp Size	Catalog Number (Pair)
30	60	263	30	60	No. 663
30	100	213	30	100	No. 216
60	100	216	60	100	No. 616
60	200	226	60	200	No. 626
100	200	2621	100	200	No. 2621
100	400	2641	100	400	No. 2641
200	400	2642	200	400	No. 2642
100	600	2661	100	600	No. 2661
200	600	2662	200	600	No. 2662
400	600	2664	400	600	No. 2664

### NON (250Vac) Catalog Numbers (Amps)

NON-1/2	NON-5	NON-40	NON-175
NON-1/2	NON-6	NON-45	NON-200
NON-3/4	NON-6 1/4	NON-50	NON-225
NON-1	NON-7	NON-60	NON-250
NON-1	NON-8	NON-65	NON-300
NON-1 1/2	NON-9	NON-70	NON-350
NON-1 1/2	NON-10	NON-75	NON-400
NON-1 3/4	NON-12	NON-80	NON-450
NON-2	NON-15	NON-90	NON-500
NON-2 1/2	NON-20	NON-100	NON-600
NON-3	NON-25	NON-110	
NON-3 3/4	NON-30	NON-125	
NON-4	NON-35	NON-150	

For superior electrical protection, Cooper Bussmann recommends upgrading NON (250Vac) and NOS (600Vac) fuse applications to Low-Peak LPN-RK (250Vac) and LPS-RK (600Vac) fuses See page 16.

### Recommended Fuse Holders & Blocks For Class K5 & H 250V & 600V Fuses

- See page 8

## Plug fuses

### W Series

**Specifications**

**Description:** Fast-acting plug fuse.

**Dimensions:** Edison base plug.

**Construction:** Brass threads with ceramic body.

**Ratings:**

- Volts — 125Vac
- Amps — ½-12A
- IR — 10,000A RMS Sym.

**Agency Information:** CE, Std. 248-11, UL Listed, Guide JEFV, File E12112.

**Features and Benefits**

- Dependable, fast-acting circuit protection with 10,000A interrupting rating for added safety when applied to existing plug fuse systems and 125-volt single-phase control circuits.

**Typical Applications**

- Replacement only in existing systems.
- For general purpose circuit protection
- Use for lighting and other non-motor circuits

**Catalog Numbers\* (Amps)**

W-½	W-2 ½	W-6	W-10
W-1	W-3	W-6 ½	W-12
W-1 ½	W-4	W-7	
W-2	W-5	W-8	

\*W-15, W-20, W-25, and W-30 plug fuses obsoleted. Suggest replacing with either T-(Amp) or TL-(Amp) plug fuses.

**Data Sheet: 1036**

**Recommended Fuse Holders For W Series Plug Fuses**

- See page 10



### SL and TL Series

**Specifications**

**Description:** Time-delay, loaded link plug fuse.

**Dimensions:**

- SL — Rejection base
- TL — Edison base

**Construction:**

- SL — Ceramic base with rejection threads
- TL — Brass threads with ceramic body

**Ratings:**

- Volts — 125Vac
- Amps — 15-30A
- IR — 10,000A RMS Sym.

**Agency Information:** CE, Std. 248-11, UL Listed, Guide JEFV, File E12112.

**Features and Benefits**

- Time-delay loaded link TL Series Edison base plug fuses pass motor overload starting currents without opening and allow closer sizing to motor load for added protection.
- Time-delay loaded link SL Series fuses provide a rejection feature (when used alone or with Fustat adapters to retrofit Edison base holders) to help prevent overfusing.

**Typical Applications**

- Small motor and inductive load circuits with high in-rush current levels.
- Used with box cover units to provide equipment protection.
- Applications benefiting from fuse rejection (SL Series only)

**Catalog Numbers (Amps)**

Type SL	Type TL
SL-15	TL-15
SL-20	TL-20
SL-25	TL-25
SL-30	TL-30

**Data Sheets: 1033 (SL) & 1035 (TL)**

**Recommended Fuse Holders For SL & TL Series Plug Fuses**

- See page 10
- See page 38 for Fustat adapters for use with SL Series



# Low Voltage, Branch Circuit Rated Fuses

## Plug fuses

### S and T Series

#### Specifications

##### Description:

Dual-element, time-delay plug fuse.

##### Dimensions:

- S — Rejection base
- T — Edison base

##### Construction:

- S — Ceramic base with rejection threads
- T — Brass threads with ceramic body

##### Ratings:

- Volts — 125Vac
- Amps — S Series: ¼-30A
- T Series: ⅓-30A
- IR — 10,000A RMS Sym.

**Agency Information:** CE, Std. 248-11, Type S and T: UL Listed (0-6¼) Guide JFHR, File E56412 (7-30A) Guide JEFV, File E12112; CSA Certified, Class 1423-01, File 53787.

#### Features and Benefits

- Time-delay, dual-element T Series Edison base plug fuses provide small motor overload protection when used with box cover units.
- Time-delay, dual-element S Series plug fuses provide a rejection feature (when used alone or with Fustat adapters to retrofit Edison base holders) to prevent overfusing of branch circuits.

#### Typical Applications

- S Series — Residential Load Centers
- T Series — Box Cover Units for small motor overload protection
- Applications benefiting from fuse rejection (S Series only)

#### Catalog Numbers (Amps)

##### S Series

S-¼	S-1	S-2	S-3 ⅓	S-6 ¼	S-14
S-⅓	S-1 ½	S-2 ¼	S-3 ½	S-7	S-15
S-½	S-1 ¼	S-5 ⅓	S-4	S-8	S-20
S-⅔	S-1 ⅓	S-2 ½	S-4 ½	S-9	S-25
S-⅞	S-1 ⅓	S-2 ⅓	S-5	S-10	S-30
S-⅞	S-1 ⅓	S-3	S-6	S-12	

##### T Series

T-⅓	T-1 ⅓	T-2 ¼	T-4	T-7	T-15
T-½	T-1 ¼	T-2 ½	T-4 ½	T-8	T-20
T-⅔	T-1 ⅓	T-2 ⅓	T-5	T-9	T-25
T-⅞	T-1 ⅓	T-3	T-5 ⅓	T-10	T-30
T-⅞	T-1 ⅓	T-3 ⅓	T-6	T-12	
T-1	T-2	T-3 ½	T-6 ¼	T-14	

**Data Sheet: 1032 (S) & 1034 (T)**

#### Recommended Fuse Holders For S & T Series Plug Fuses

- See page 10
- See next column for Fustat adapters for use with S Series



### Fustat Fuse Adapters



#### Specifications

**Description:** Adapters for using Type S and SL rejection fuses in Edison base fuse sockets.

#### Features and Benefits

- Fustat adapters screw into the “Edison” thread fuse sockets of standard fuse boxes making it easy to retrofit existing fuse installations
- Available in various amp ratings to cover a wide range of rating requirements

#### Typical Applications

- Plug fuse installations where it is desirable to restrict fuse amp ratings

#### Catalog Numbers (Amps)

SA-1*	SA-3⅓*	SA-10*
SA-1¼*	SA-4*	SA-15**
SA-1⅓*	SA-5*	SA-20**
SA-2*	SA-6¼*	SA-30**
SA-2½*	SA-8*	

ENA (Edison base neutral)

EDA (Edison base dummy)

\* Single motor circuits.

\*\* Branch circuits.

#### Fustat® Adapters for Small Motor Protection\*

Adapter	Accepts Fuses
SA-1	S-1 or smaller
SA-1 ¼	S-1 ¼ or smaller
SA-1 ⅓	S-1 ⅓ or smaller
SA-2	S-2 or S-1 ⅓
SA-2 ½	S-2 ½ to S-1 ⅓
SA-3 ⅓	S-3 ⅓ to S-1 ⅓
SA-4	S-4 to S-3 ½
SA-5	S-5 to S-3 ½
SA-6 ¼	S-6 ¼ to S-3 ½
SA-8	S-8 to S-7
SA-10	S-10 to S-7
SA-15	S-15 to S-7
SA-20	S-20
SA-30	S-30 to S-20

\* Both motor running and short-circuit protection.

#### Fustat® Adapters for Branch Circuit Protection

Adapter	Accepts Fuses
SA-15	S-15 to S-7
SA-20	S-20
SA-30	S-25
SA 30	S-30 to S-20