

## Fuseology



<i>Terms and Definitions</i>	<b>177-181</b>
<i>Electrical Safety Guide</i>	<b>182-183</b>
<i>Fuse Application Guide</i>	<b>184-203</b>
<i>Motor Protection Tables</i>	<b>204-206</b>
<i>Condensed Cross Reference</i>	<b>207</b>
<i>Alphanumeric Index</i>	<b>208</b>

## Fuseology

### Introduction

Fuseology provides the information needed to choose the correct types of Littelfuse POWR-GARD™ fuses for most applications. Definition of Terms is followed by Overcurrent Protection Fundamentals. If there are any questions or if additional data is needed for a specific use, call the Littelfuse Technical Support and Engineering Service Group at **1-800-TEC-FUSE (1-800-832-3873)** or visit us online at [www.littelfuse.com/technicalcenter](http://www.littelfuse.com/technicalcenter).

**Call 1-800-TEC-FUSE for  
Technical Support and  
Engineering Services or visit  
[www.littelfuse.com/technicalcenter](http://www.littelfuse.com/technicalcenter)**

<b>Definitions</b>	<b>177-181</b>
<b>Electrical Safety</b>	<b>182-183</b>
<b>Overcurrent Protection Fundamentals (Fuses and How They Work) Index</b>	<b>184</b>
<i>Why Overcurrent Protection</i>	184
<i>What is Quality Overcurrent Protection</i>	184
<i>Overcurrent Types and Effects</i>	184
<i>Fuse Characteristics (600 volts and below)</i>	185
<i>Time-Current Characteristics</i>	186-187
<i>Peak Let-through Charts</i>	187-189
<i>Fuse Ampere Ratings</i>	189
<i>Fuse Dimensions</i>	189
<i>Fuse Coordination (Developing a Selective System)</i>	190-191
<i>Component Short-circuit Protecting Ability</i>	190
<b>UL/CSA Fuse Classes and Their Applications</b>	<b>192-193</b>
<b>Fuses for Specific Applications (600 Volts and Below) Index</b>	<b>194</b>
<i>Protecting Service Entrance and Feeder Conductors</i>	194
<i>Main Services and Feeders</i>	194
<i>Motor Protection</i>	194-198
<i>Motor Overload Protection (running overcurrent)</i>	195-197
<i>Motor Feeder (100% Motor Load) Protection over 600A</i>	197
<i>Motor Branch Circuit Protection over 600A</i>	197
<i>Motor Controller (Starter) Protection over 600A</i>	197
<i>Control Transformer Protection</i>	197-198
<i>Primary Fusing With Secondary Fusing</i>	198
<i>Secondary Fusing of Transformers</i>	198
<i>Lighting Fixture Protection</i>	198
<i>Street Lighting &amp; Other Weatherproof Overcurrent Protection</i>	198
<i>Cable Short-circuit Protection (Cable Limiter Application)</i>	199
<i>Semiconductor and Solid-state Device Protection</i>	199
<i>Effect of Ambient Temperature on Fuses</i>	199
<b>Medium Voltage Protection (2400 volts to 38.0 kV)</b>	<b>200-203</b>
<b>Motor Protection Tables</b>	<b>204-206</b>

## Fuse Application Guide

### Definitions

### Definition of Terms Frequently Used When Selecting Overcurrent Protection

#### AIC or A.I.C.

See Interrupting Capacity.

#### AIR or A.I.R.

See Interrupting Rating.

#### Ambient Temperature

The air temperature surrounding a device. For fuses or circuit breakers in an enclosure, the air temperature within the enclosure.

#### Ampacity

The current in amperes that a conductor can carry continuously under the conditions of use without exceeding its temperature rating. It is sometimes informally applied to switches or other devices. These are more properly referred to by their ampere rating.

#### Ampere Rating

The current rating, in amperes, that is marked on fuses, circuit breakers, or other equipment.

#### Ampere-Squared-Seconds ( $I^2t$ )

A means of describing the thermal energy generated by current flow. When a fuse is interrupting a current within its current-limiting range, the term is usually expressed as melting, arcing, or total clearing  $I^2t$ .

**Melting  $I^2t$**  is the heat energy passed by a fuse after an overcurrent occurs and until the fuse link melts. It equals the rms current squared multiplied by melting time in seconds. For times less than 0.004 seconds, melting  $I^2t$  approaches a constant value for a given fuse.

**Arcing  $I^2t$**  is the heat energy passed by a fuse during its arcing time. It is equal to the rms arcing current squared (see below), multiplied by arcing time.

**Clearing  $I^2t$**  (also Total Clearing  $I^2t$ ) is the ampere-squared seconds ( $I^2t$ ) through an overcurrent device from the inception of the overcurrent until the current is completely interrupted. Clearing  $I^2t$  is the sum of the Melting  $I^2t$  and the Arcing  $I^2t$ .

#### Arc-Flash

The sudden release of heat energy and intense light at the point of an arc. Can be considered a short-circuit through the air, usually created by accidental contact between live conductors.

#### Arcing Current (See Figure 1)

The current that flows through the fuse after the fuse link has melted and until the circuit is interrupted.

#### Arcing $I^2t$

See Ampere-Squared-Seconds ( $I^2t$ ).

#### Arcing Fault

A short-circuit that arcs at the point of fault. The arc impedance (resistance) tends to reduce the short-circuit current. Arcing faults may turn into bolted faults by welding of the faulted components. Arcing faults may be phase-to-phase or phase-to-ground.

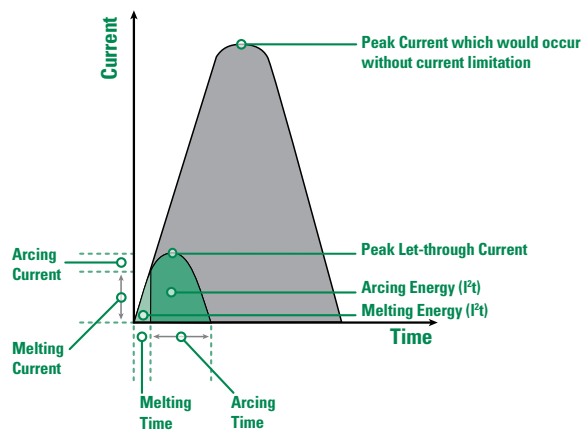

Figure 1

Showing arcing and melting currents and arcing, melting and clearing times.

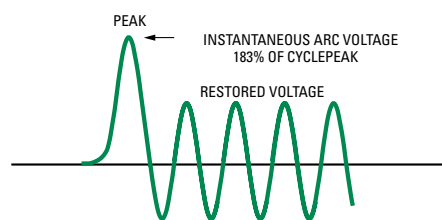

Figure 2

#### Arcing Time (See Figure 1)

The time between the melting of a fuse link, or parting of circuit breaker contacts, until the overcurrent is interrupted.

#### Arc Voltage (See Figure 2)

Arc voltage is a transient voltage that occurs across an overcurrent protection device during the arcing time. It is usually expressed as peak instantaneous voltage ( $V_{peak}$  or  $E_{peak}$ ), rarely as rms voltage.

#### Asymmetrical Current

See Symmetrical Current.

#### Available Short-Circuit Current (also Available or Prospective Fault Current)

The maximum rms Symmetrical Current that would flow at a given point in a system under bolted-fault conditions. Short-circuit current is maximum during the first half-cycle after the fault occurs. See definitions of Bolted Fault and Symmetrical Current.

#### Blade Fuse

See Knife Blade Fuse.

#### Body

The part of a fuse enclosing the fuse elements and supporting the contacts. Body is also referred to as cartridge, tube, or case.

## Fuse Application Guide

### Definitions

#### **Bolted Fault**

A short-circuit that has no electrical resistance at the point of the fault. It results from a firm mechanical connection between two conductors, or a conductor and ground. Bolted faults are characterized by a lack of arcing. Examples of bolted faults are a heavy wrench lying across two bare bus bars, or a crossed-phase condition due to incorrect wiring.

#### **Cartridge Fuse**

A fuse that contains a current-responsive element inside a tubular fuse body with cylindrical ferrules (endcaps).

#### **Case Size (also Cartridge Size)**

The maximum allowable ampere rating of a cartridge fuse having defined dimensions and shape. For example, case sizes for UL Listed Class H, K, J, RK1, and RK5 are 30, 60, 100, 200, 400, and 600 amperes. The physical dimensions vary with fuse class, voltage, and ampere rating. UL Standards establish the dimensions for each UL Fuse Class. This catalog's product section contains case size dimensions for all Littelfuse POWR-GARD™ fuses.

#### **Clearing I<sup>2</sup>t**

See Ampere-Square-Seconds (I<sup>2</sup>t).

#### **Clearing Time (see Figure 1)**

The time between the initiation of an overcurrent condition to the point at which the overcurrent is interrupted. Clearing Time is the sum of Melting Time and Arcing Time.

#### **Contacts (Fuse)**

The external metal parts of the fuse used to complete the circuit. These consist of ferrules, caps, blades or terminals, as shown in this catalog.

#### **Coordination or Coordinated System**

See Selective Coordination.

#### **Continuous Load**

An electrical load where the maximum current is expected to continue for 3 hours or more.

#### **Current-limiting Fuse (See Figure 3)**

A fuse which, when interrupting currents within its current-limiting range, reduces the current in the faulted circuit to a magnitude substantially less than that obtainable in the same circuit if the device was replaced with a solid conductor having comparable impedance. To be labeled "current-

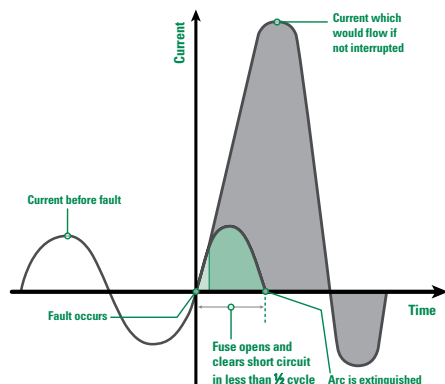

Figure 3

limiting," a fuse must mate with a fuseblock or fuseholder that has either a rejection feature or dimensions that will reject non-current-limiting fuses.

#### **Current-limiting Range**

For an individual overcurrent protective device, the current-limiting range begins at the lowest value of rms symmetrical current at which the device becomes current-limiting (the threshold current) and extends to the maximum interrupting capacity of the device. See definitions of Threshold Current and Interrupting Capacity.

#### **Current Rating**

See Ampere Rating.

#### **Dual-element Fuse**

A fuse with internal construction consisting of a separate time-delay overload element(s) that interrupts overcurrents up to approximately 500%-600% of its nominal rating, plus separate fuse links that quickly open higher value currents. All dual-element fuses have time delay, but, since there are other methods of achieving time delay, not all time-delay fuses have dual-element construction. See Time-Delay Fuse.

#### **Element**

A fuse's internal current-carrying parts that melt and interrupt the current when subjected to an overcurrent of sufficient duration or value. Also called fuse link.

#### **Fast-Acting Fuse**

May also be termed Normal-opening fuse.

A fuse that has no intentional, built-in, time delay. Actual opening time is determined by the fuse class, the overcurrent, and other conditions. Fast-acting is indicated on the fuse label by "Fast-Acting", "F-A", "F", or other suitable marking.

#### **Fault**

Same as Short-Circuit and used interchangeably.

#### **Fault Current**

Same as Short-Circuit current.

#### **Filler**

A material, such as granular quartz, used to fill a section or sections of a fuse and aid in arc quenching.

#### **Fuse**

An overcurrent protective device consisting of one or more current-carrying elements enclosed in a body fitted with contacts, so that the fuse may be readily inserted into or removed from an electrical circuit. The elements are heated by the current passing through them, thus interrupting current flow by melting during specified overcurrent conditions.

#### **Ground Fault**

A short-circuit caused by insulation breakdown between a phase conductor and a grounded object or conductor.

#### **I<sup>2</sup>t**

See Ampere-Squared-Seconds (I<sup>2</sup>t).

#### **IEC Type 2 Protection**

Fused protection for control components that prevents damage to these

## Fuse Application Guide

### Definitions

components under short-circuit conditions. A more complete discussion of this subject is included in the Motor and Motor Circuit Protection Section. See definition of No Damage.

#### **Instantaneous Peak Current ( $I_p$ or $I_{peak}$ )**

The maximum instantaneous current value developed during the first half-cycle (180 electrical degrees) after fault inception. The peak current determines magnetic stress within the circuit. See Symmetrical Current.

#### **Interrupting Capacity (AIC)**

The highest available symmetrical rms alternating current (for DC fuses the highest direct current) at which the protective device has been tested, and which it has interrupted safely under standardized test conditions. The device must interrupt all available overcurrents up to its interrupting capacity. Also commonly called interrupting rating. See Interrupting Rating below.

#### **Interrupting Rating (IR, I.R., AIR or A.I.R.)**

The highest RMS symmetrical current, at specified test conditions, which the device is rated to interrupt. The difference between interrupting capacity and interrupting rating is in the test circuits used to establish the ratings.

#### **Inverse-time Characteristics**

A term describing protective devices whose opening time decreases with increasing current.

#### **IR or I.R. (also AIR or A.I.R.)**

See Interrupting Rating above.

#### **Kiloamperes (kA)**

1,000 amperes.

#### **Knife Blade Fuse**

Cylindrical or square body fuses with flat blade terminals extending from the fuse body. Knife blades may be designed for insertion into mating fuse clips, and/or to be bolted in place. Knife blade terminals may include a rejection feature that mates with a similar feature on a fuse block of the same class.

#### **Melting Current (see Figure 1)**

The current that flows through the fuse from the initiation of an overcurrent condition to the instant arcing begins inside the fuse.

#### **Melting $Pt$**

See Ampere-Squared-Seconds ( $I^2t$ ).

#### **Melting Time (see Figure 1)**

The time span from the initiation of an overcurrent condition to the instant arcing begins inside the fuse.

#### **NEC**

In general, the National Electrical Code® (NEC®). Specifically, as referenced herein, NEC refers to NFPA Standard 70, National Electrical Code®, National Fire Protection Association, Quincy, MA 02269.

Sections of the NEC reprinted herein, and/or quotations therefrom, are done so with permission. The quoted and reprinted sections are not the official position of the National Fire Protection Association, which is represented only by the Standard in its entirety. Readers are cautioned that not all authorities have adopted the most recent edition of the NEC; many are still using earlier editions.

#### **No Damage**

A term describing the requirement that a system component be in essentially the same condition after the occurrence of a short-circuit as prior to the short-circuit.

#### **Non-renewable Fuse**

A fuse that must be replaced after it has opened due to an overcurrent. It cannot be restored to service.

#### **Normal-opening Fuse**

See Fast-Acting Fuse.

#### **One-time Fuse**

Technically, any non-renewable fuse. However, the term usually refers to UL Class H fuses and to fast acting Class K5 fuses. Such fuses are not current-limiting and do not have a rejection feature. One-time fuses are also referred to as "Code" fuses.

#### **Overcurrent**

Any current larger than the equipment, conductor, or devices are rated to carry under specified conditions.

#### **Overload**

An overcurrent that is confined to the normal current path (e.g., not a short-circuit), which if allowed to persist, will cause damage to equipment and/or wiring.

Additional information regarding fuse applications for overload protection can be found later in this Fuseology section.

#### **Peak Let-through Current (See Figure 4)**

The maximum instantaneous current that passes through an overcurrent protective device during its total clearing time when the available current is within its current-limiting range.

#### **Power Factor (X/R)**

As used in overcurrent protection, power factor is the relationship between the inductive reactance (X) and the resistance (R) in the system during a fault. Under normal conditions a system may be operating at a 0.85 power factor (85%). When a fault occurs, much of the system resistance is shorted out and the power factor may drop to 25% or less. This may cause the current to become asymmetrical. See definition of Symmetrical Current. The UL test circuits used to test fuses

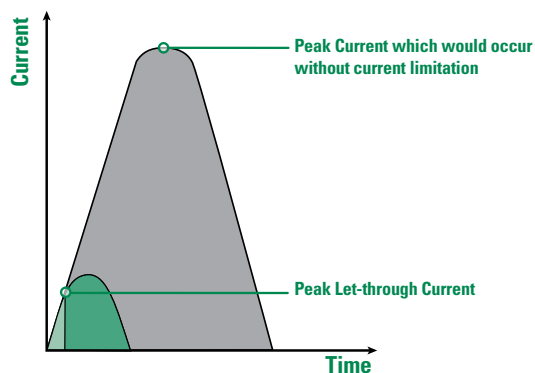

Figure 4

## Fuse Application Guide

### Definitions

with interrupting ratings exceeding 10,000 amperes are required to have a power factor of 20% or less. Since the power factor of test circuits tends to vary during test procedures, actual test circuits are usually set to a 15% power factor. The resulting asymmetrical current has an rms value of 1.33 times the available symmetrical rms. The instantaneous peak current of the first peak after the fault is 2.309 times the available symmetrical rms.

#### Prospective Current

See Available Short-Circuit Current.

#### Rating

A designated limit of operating characteristics based on definite conditions such as current rating, voltage rating and interrupting rating.

#### Rectifier Fuse

See Semiconductor Fuse.

#### Rejection Feature

The physical characteristics of a fuse block or fuseholder that prevents the insertion of a fuse unless it has mating characteristics. This may be done through the use of slots, grooves, projections, or the actual physical dimensions of the fuse. This feature prevents the substitution of fuses of a Class or size other than the Class and size intended.

#### Renewable Element (also Renewable Link)

A renewable fuse current-carrying part that is replaced to restore the fuse to a functional condition after the link opens due to an overcurrent condition.

#### Renewable Fuse

A fuse that may be readily restored to service by replacing the renewable element after operation.

#### Selective Coordination (See Figure 5)

In a selectively coordinated system, only the protective device immediately on the line side of an overcurrent opens. Upstream protective devices remain closed. All other equipment remains in

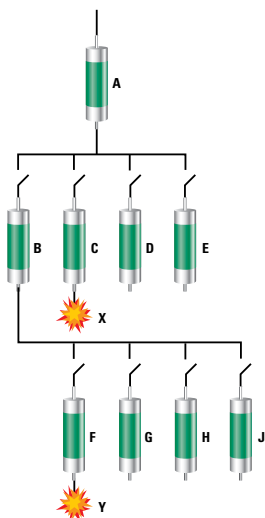

**In a selective system:**  
For a fault at "X" only fuse "C" will open.  
For a fault at "Y" only fuse "F" will open.

Figure 5

### CURRENT FLOW

In a "normal" circuit, current is determined by load IMPEDANCE



(Heavy lines indicate increased current)

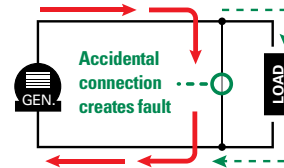

In a short-circuit, current is limited only by impedance of fault path. Current may increase to many times load current.

Figure 6

service, which simplifies the identification and location of overloaded equipment or short-circuits. For additional information, refer to the Fuse Coordination pages of this Fuseology section.

#### Semiconductor Fuse

A fuse specifically designed to protect semiconductors such as silicon rectifiers, silicon-controlled rectifiers, thyristors, transistors, and similar components. For additional information, refer to the Semiconductor Section of this catalog.

#### Short-Circuit (See Figure 6)

A current flowing outside its normal path. It is caused by a breakdown of insulation or by faulty equipment connections. In a short-circuit, current bypasses the normal load. Current is determined by the system impedance (AC resistance) rather than the load impedance. Short-circuit currents may vary from fractions of an ampere to 200,000 amperes or more.

#### Short-Circuit Rating

The maximum RMS symmetrical short-circuit current at which a given piece of equipment has been tested under specified conditions, and which, at the end of the test is in essentially the same condition as prior to the test. Short-circuit ratings (also called withstand ratings) apply to equipment that will be subjected to fault currents, but which are not required to interrupt them. This includes switches, busway (bus duct), switchgear and switchboard structures, motor control centers and transformers.

Most short-circuit ratings are based on tests which last three complete electrical cycles (0.05 seconds). However, if the equipment is protected during the test by fuses, or by a circuit breaker with instantaneous trips, the test duration is the time required for the overcurrent protective device to open the circuit.

When so protected during testing, the equipment instructions and labels must indicate that the equipment shall be protected by a given fuse class and rating or by a specific make, type, and rating of circuit breaker.

## Fuse Application Guide

### Definitions

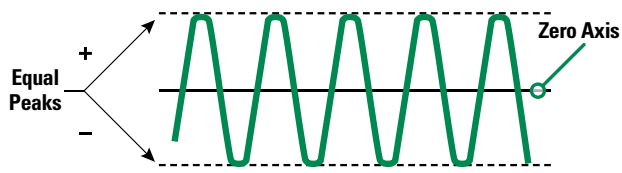

**Figure 7**  
Symmetrical Current

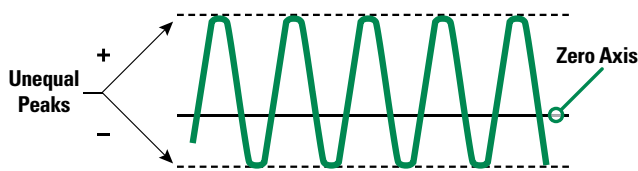

**Figure 8**  
Asymmetrical Current

Circuit breakers equipped with short-delay trip elements instead of instantaneous trip elements have withstand (short-circuit) ratings in addition to their interrupting rating. The breaker must be able to withstand the available fault current during the time that opening is delayed.

#### Symmetrical Current

The terms "Symmetrical Current" and "Asymmetrical Current" describe an AC wave symmetry around the zero axis. The current is symmetrical when the peak currents above and below the zero axis are equal in value, as shown in **Figure 7**. If the peak currents are not equal, as shown in **Figure 8**, the current is asymmetrical.

The degree of asymmetry during a fault is determined by the change in power factor (X/R) and the point in the voltage wave when the fault occurs. See definition of Power Factor. In general, lower short-circuit power factors increase the degree of asymmetry.

#### Threshold Current

The minimum current for a given fuse size and type at which the fuse becomes current-limiting. It is the lowest value of available rms symmetrical current that will cause the device to begin opening within the first 1/4 cycle (90 electrical degrees) and completely clear the circuit within 1/2 cycle (180 electrical degrees). The approximate threshold current can be determined from the fuse's peak let-through charts.

See **Figure 9**.

#### Threshold Ratio

The threshold current divided by the ampere rating of a specific type or class overcurrent device. A fuse with a threshold ratio of 15 becomes current-limiting at 15 times its current rating.

#### Time-Delay Fuse

Fuses that have an intentional, built-in delay in opening. When compared to fast-opening fuses, time-delay fuses have an increased opening time for overcurrents between approximately 200% and 600% of the fuse's current rating. Time-delay is indicated on the fuse label by "Time-Delay", "T-D", "D", or other suitable marking. Time-delay in the

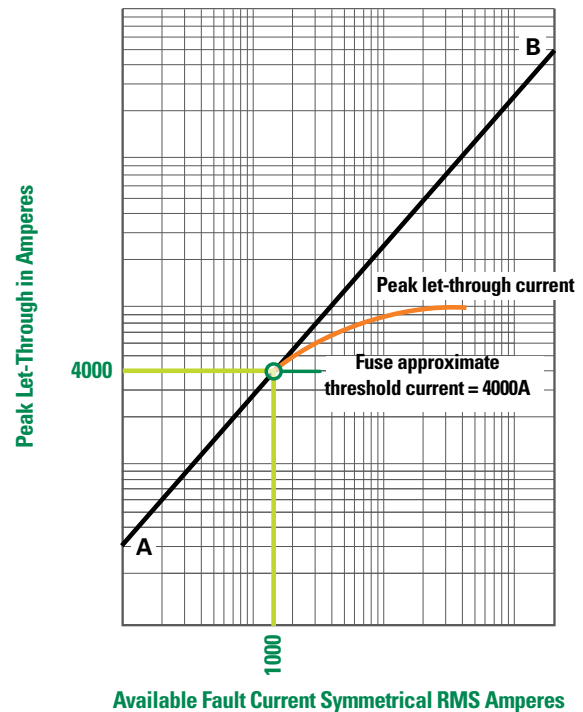

**Figure 9**

overload range (200%-600% of the fuse rating) permits the fuse to withstand system switching surges, motor starting currents, and other harmless temporary overcurrents.

UL Standards require time-delay Class H, K, RK1, RK5, and J fuses to hold 500% of their normal current rating for a minimum of 10 seconds. They must also pass the same opening time tests (135% and 200% of current rating) as fast acting fuses.

Time-delay Class CC, CD, G, Plug, and Miscellaneous fuses have different requirements. See the corresponding descriptions given in the Product Information Section.

For the UL Standard, Class L fuses have no standard time-delay. The time-delay varies from type to type for a given manufacturer, as well as from manufacturer to manufacturer. For reference, Littelfuse KLPC series POWR-PRO® fuses do hold 500% of rated current for a minimum of ten seconds.

#### Voltage Rating

The maximum rms AC voltage and/or the maximum DC voltage at which the fuse is designed to operate. For example, fuses rated 600 volts and below may be applied at any voltage less than their rating. There is no rule for applying AC fuses in DC circuits such as applying the fuse at half its AC voltage rating. **Fuses used on DC circuits must have DC ratings.**

#### Withstand Rating

See Short-Circuit.

## Electrical Safety Guide

Electrical safety is an important issue for employers and employees alike. Unfortunately there are still about 30,000 electrical accidents occurring each year, each of them potentially costing up to \$15 million, and the number is increasing.

OSHA requires all employers to perform a hazard assessment of their facilities and train their employees to become qualified to perform a specific task. Being aware, following safety regulations, codes and standards, and using protective devices will minimize hazards and help establish safer work practices.

### FACTS

- **There are approximately 30,000 electrical shock accidents every year.**
- **Over 3600 disabling electrical contact injuries occur annually.**
- **Over 2000 workers are sent to burn centers each year with severe Arc-Flash burns.**
- **Over 1000 electrical workers die each year from workplace accidents.**
- **60% of workplace accident deaths are caused by burn injuries.**
- **Electrocutions are the 4th leading cause of traumatic occupational fatalities.**
- **Estimates show that 10 Arc-Flash incidents occur every day in the U.S.**
- **97% of all electricians have been shocked or injured on the job.**
- **Medical costs per person can exceed \$4 million for severe electrical burns.**
- **Total costs per electrical incident can exceed \$15 million.**
- **In the year 2002, work injuries cost Americans \$146.6 billion.**

#### OSHA Standard 29 CFR Part 1910 Subpart S (electrical)

generally addresses safety standards, work practices, and maintenance requirements.

#### NFPA 70E Standard for Electrical Safety in the Workplace

concentrates on safety requirements to protect employees. OSHA commonly is referred to as the "Shall" and NFPA 70E as the "How" with regards to electrical safety.

#### Both OSHA and NFPA 70E reinforce the need for Electrical Hazard Analysis.

The analysis should address all potential electrical hazards including shock, Arc-Flash, Arc-Blast, and burns. NFPA 70E Article 110.8(B)(1) specifically requires Electrical Hazard Analysis within all areas of the electrical system that operate at 50 volts or greater. The results of the Electrical Hazard Analysis will determine the work practices, protection boundaries, personal protective equipment to be used, and other procedures to protect employees from an Arc-Flash or contact with live conductors.

#### Implementing and following a well designed Electrical Safety Program will protect employees and employers against:

- **Injury to personnel**
- **Increased insurance and workman compensation**
- **Lost or unusable materials**
- **Unplanned equipment repair or replacement**
- **OSHA citations and fines**
- **Multi-million dollar lawsuits**
- **Possible bankruptcy**

***Electrical Safety is not an option; it is absolutely necessary for both workers and employers.***

# Electrical Safety Guide

The following is a brief overview of requirements for working on electrical equipment.

**NOTE: Only the complete standards constitute the law or regulation and all parts must be followed where applicable.**

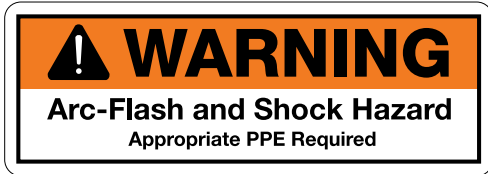

## Understand and follow NFPA and OSHA guidelines

Allow only "Qualified" individuals to perform work. Qualified workers must be knowledgeable on the equipment and the hazards that exist and receive documented training. For more information refer to OSHA 1910.332 and NFPA 70E Article 110.6(D)(1).

Establish a "Safe Work Condition" and work on system components de-energized whenever possible. Consult NFPA 70E Article 120.1 for establishing an Electrically Safe Work Condition.



## Develop an Electrical Safety Program

Determine available fault currents and hazard risks at points where there is the potential for contact with an energized part. In many cases, this requires a complete Hazard Risk Assessment. As a result, the entire electrical system is analyzed and the one-line diagram for the facility is reviewed and updated. The outcome is used to determine the Hazard Risk Category (0 to 4), required level of PPE, Protection Boundaries and equipment that requires warning labels. Refer to OSHA 1910.132(d) and NFPA 70E Article 110.8(B)(1) for more information on Electrical Hazard Analysis.



## Establish an Electrical Safety Program.

It should control and re-engineer the processes in the workplace to insure Electrical Safety including: hazard assessments, labeling of equipment, training programs, energized work permits and using current-limiting devices to minimize hazards. Refer to NFPA 70E Article 110.7 for more information on establishing an Electrical Safety Program. Develop formal training for equipment operators, service technicians and any other employees that might come in contact with the identified hazard. "Qualify" them for hazard preparations and contingencies (preparations prior to servicing electrical systems or coming within boundaries of electrical hazards). For more information refer to OSHA 1910.332 and NFPA 70E Article 110.6.



## Communicate the hazards to employees

Train your employees.

Label equipment and service entrances of the "Hazards Assessed." Refer to NEC Article 110.16 for Warning Label Requirements.

Create a safety culture and support safety processes and awareness such as: Deenergize and Verify, "Test Before Touch", Lockout/Tagout, the proper use of PPE and insulated tools, providing barriers to warn and restrict access to unqualified personnel, etc.



## Select the safest circuit protection devices to minimize electrical hazards

**WARNING**  
Arc-Flash and Shock Hazard  
Appropriate PPE Required

Flash Protection Boundary 32 inches Available Fault Current 35 kA  
Hazard Risk Category 1 System Voltage 480 VAC  
Incident Energy at 18" (cal/cm<sup>2</sup>) 2.77 cal/cm<sup>2</sup>

**REQUIRED PPE**

<input type="checkbox"/> Hard Hat	<input type="checkbox"/> Flash Hood	<input type="checkbox"/> Voltage Rated Gloves	<input type="checkbox"/> FR Pants
<input type="checkbox"/> Safety Glasses	<input type="checkbox"/> Ear Protection	<input type="checkbox"/> Leather Gloves	<input type="checkbox"/> FR coverall
<input type="checkbox"/> Safety Goggles	<input type="checkbox"/> T-shirt	<input type="checkbox"/> Cotton Underwear	<input type="checkbox"/> Flash Suit
<input type="checkbox"/> Face Shield	<input type="checkbox"/> Long Sleeve Shirt	<input type="checkbox"/> Long Pants	<input type="checkbox"/> Leather Shoes
	<input type="checkbox"/> FR Shirt		

**SHOCK HAZARD APPROACH BOUNDARIES**

Limited 42 inches Restricted 12 inches Prohibited 1 inch

Equipment ID: Bus: SERVICE4 Date: 05/12/05

**Littelfuse**  
POWR-GARD™ Products

**800-TEC-FUSE**  
www.littelfuse.com

## Fuse Application Guide

### Overcurrent Protection Fundamentals

#### Overcurrent Protection Fundamentals (Fuses and How They Work)

##### Introduction

An important part of developing quality overcurrent protection is an understanding of system needs and overcurrent protective device fundamentals. This section discusses these topics with special attention to the application of fuses. If you have additional questions, call our Technical Support and Engineering Services Group at 1-800-TEC-FUSE (1-800-832-3873). Definitions of terms used in this section are located in the preceding section.

INDEX	Page
<i>Why Overcurrent Protection?</i> .....	184
<i>What is Quality Overcurrent Protection?</i> .....	184
<i>Overcurrents, Types and Effects</i> .....	184
<b>Overloads</b> .....	184
<b>Short-Circuits</b> .....	185
<i>Fuse Characteristics</i> (600 volts and below).....	185
<b>Voltage Rating</b> .....	185
<b>Interrupting Rating</b> .....	185-186
300,000 AIC Fuses.....	186
<i>Time Current Characteristics</i> .....	186
<b>Overloads</b> .....	186
Fast-Acting Fuses .....	186
Time-Delay (Dual-Element) Fuses .....	186
Very Fast-Acting Fuses .....	187
<b>Short Circuits</b> .....	187
Current-Limiting Fuses.....	187
Fast-Acting Fuses .....	187
Dual-Element (Time-Delay) Fuses .....	187
Very Fast-Acting Fuses .....	187
<b>Time-current Curves</b> .....	187
<i>Peak Let-through Charts</i> .....	187
<b>Using the Peak Let-through Charts</b> ("up-over-and-down") .....	188-189
<i>Fuse Ampere (current) Ratings</i> .....	189
<i>Fuse Dimensions</i> .....	189
<i>Fuse Coordination, Selective Systems</i> .....	190-191
<i>Component Short-circuit Protecting Ability</i> .....	190
<i>UL/CSA Fuse Classes and Their Applications</i> .....	192-193

##### Why Overcurrent Protection?

All electrical systems eventually experience overcurrents. Unless removed in time, even moderate overcurrents quickly overheat system components, damaging insulation, conductors, and equipment. Large overcurrents may melt conductors and vaporize insulation. Very high currents produce magnetic forces that bend and twist bus bars. They can pull cables from their terminals and crack insulators and spacers.

Too frequently, fires, explosions, poisonous fumes and panic accompany uncontrolled overcurrents. They not only damage electrical systems and equipment, but may cause injury or death to personnel.

To reduce these hazards, the National Electrical Code® (NEC®), OSHA regulations, and other applicable design and installation standards require overcurrent protection that will disconnect overloaded or faulted equipment.

Industry and governmental organizations have developed performance

standards for overcurrent devices and testing procedures that show compliance with the standards and with the NEC. These organizations include: the American National Standards Institute (ANSI), National Electrical Manufacturers Association (NEMA), and the National Fire Protection Association (NFPA) working with Nationally Recognized Testing Laboratories (NRTL) such as Underwriters Laboratories (UL).

Electrical systems must meet applicable code requirements including those for overcurrent protection before electric utilities can provide electric power to a facility.

##### What is Quality Overcurrent Protection?

A system with quality overcurrent protection has the following characteristics:

1. Meets all legal requirements, such as NEC, OSHA, local codes, etc.
2. Provides maximum safety for personnel, exceeding minimum code requirements as necessary.
3. Minimizes overcurrent damage to property, equipment, and electrical systems.
4. Provides coordinated protection. Only the protective device immediately on the line side of an overcurrent opens to protect the system.
5. Is cost effective. Provides reserve interrupting capacity for future growth. Not subject to obsolescence. Requires minimum maintenance that can be done by regular maintenance personnel using readily available tools and equipment.

##### Overcurrent Types and Effects

An overcurrent is any current that exceeds the ampere rating of conductors, equipment, or devices under conditions of use. The term "overcurrent" includes both overloads and short-circuits.

##### Overloads

An overload is an overcurrent that is confined to normal current paths. There is no insulation breakdown.

**Sustained** overloads are commonly caused by installing excessive equipment such as additional lighting fixtures. They are also caused by overloading mechanical equipment and by equipment breakdown such as failed bearings. If not disconnected within established time limits, sustained overloads eventually overheat circuit components causing thermal damage to insulation and other system components.

Overcurrent protective devices must disconnect circuits and equipment experiencing continuous or sustained overloads before overheating occurs. Even moderate insulation overheating seriously reduces its life. For example, motors overloaded by only 15% may have less than 50% insulation life.

**Temporary** overloads occur frequently. They may be caused by temporary equipment overloads such as a machine tool taking too deep of a cut, or may result from starting inductive loads, such as motors. Since temporary overloads are, by definition, harmless, overcurrent protective devices should not open the circuit.

Fuses selected must have sufficient time-delay to allow motors to start

## Fuse Application Guide

### Overcurrent Protection Fundamentals

and temporary overloads to subside. However, should the overcurrent continue, fuses must open before system components are damaged. Littelfuse POWR-PRO® and POWR-GARD™ time-delay fuses are designed to meet these needs. They hold 500% current for a minimum of ten seconds, yet open quickly on higher values of current. Even though government mandated high efficiency motors and NEMA design E motors have much higher locked rotor currents, POWR-PRO time-delay fuses such as the FLSR\_ID, LLSRK\_ID, or IDSR series have sufficient time-delay to permit motors to start when the fuses are properly selected in accordance with the NEC.

#### Short-Circuits

##### Types of Short-Circuits

Short-circuits are divided into bolted faults, arcing faults and ground faults. Each are defined in the Definition section.

##### Causes of Short-Circuits

A short-circuit is current flowing outside of its normal path. It is caused by an insulation breakdown or faulty connection. During a circuit's normal operation, the connected load determines current. During a short-circuit, the current bypasses load and the current takes a "shorter path," hence: short-circuit. Since there is no load impedance, only the total distribution system's impedance from the utility's generators to the fault will limit current flow. **See Figure 6.**

Many electrical systems have single-phase impedance of 0.005 ohms or less. Applying Ohm's Law ( $I = E/Z$  for AC systems), a 480 volt single-phase circuit with a ten ohm load impedance would draw 48 amperes ( $480/10 = 48$ ). If, when the load is shorted, the same circuit has a 0.005 ohm system impedance, the available fault current would be 96,000 amperes ( $480/0.005 = 96,000$ ). Short-circuits are currents out of their normal path and regardless of their value, they must be removed quickly.

##### Effects of Short-Circuit Currents

If not removed quickly, the large currents associated with short-circuits may have three profound effects on an electrical system: heating, magnetic stress, and arcing.

**Heating.** Current passing through an electrical system heats every part of it. When overcurrents are large enough, heating is practically instantaneous. The energy in such overcurrents is measured in ampere-squared seconds ( $I^2t$ ). An overcurrent of 10,000 amperes that lasts for 0.01 seconds has an  $I^2t$  of 1,000,000. If the current could be reduced to 1,000 amperes for the same period of time,  $I^2t$  would be reduced to 10,000 — only one percent of the original value. If the current in a conductor increases 10 times, the  $I^2t$  increases 100 times. A current of only 7,500 amperes can melt a #8 AWG copper wire in 0.1 second. Within eight milliseconds (0.008 seconds or one-half cycle), a current of 6,500 amperes can raise the temperature of #12 AWG THHN thermoplastic insulated copper wire from its operating temperature of 75°C to its maximum short-circuit temperature of 150°C.

Currents larger than this may immediately vaporize organic insulations. Arcs at the point of fault or from mechanical switching such as automatic transfer switches or circuit breakers may ignite the vapors causing violent explosions and electrical flash.

**Magnetic stress.** Magnetic stress (or force) is a function of the peak

current squared. Fault currents of 100,000 amperes can exert forces of more than 7,000 lb. per foot of bus bar. These stresses may injure insulation, pull conductors from terminals, and stress equipment terminals sufficiently to cause damage.

**Arcing.** Arcing at the point of fault melts and vaporizes the conductors and components involved in the fault. The arcs often burn through raceways and equipment enclosures showering the area with molten metal that quickly starts fires and/or injures personnel in the area. Additional short-circuits are often created when vaporized material is deposited on insulators and other surfaces. Sustained arcing-faults vaporize organic insulation. These vapors may explode or burn.

#### Fuse characteristics (600 volts and below)

Since overcurrent protection is crucial to reliable electrical system operation and safety, overcurrent device selection and application should be carefully considered. When selecting fuses, the following parameters need to be evaluated:

#### Voltage Rating

Fuse voltage ratings must equal or exceed the circuit voltage where the fuses will be installed, and fuses used in DC circuits must be rated for DC. Exceeding the voltage ratings or using an AC only fuse in a DC circuit could result in violent destruction of the fuse. Standard 600 volt and below fuses may be applied at any voltage less than their rating. For example, a 600 volt fuse may be used in a 277 volt or even a 32 volt system.

**NOTE:** This does not apply to semiconductor fuses and medium voltage fuses. See the semiconductor and medium voltage fuse application data later in this section for voltage limitations of these fuses.

UL Listed low-voltage power fuses are available with AC voltage ratings of 125, 250, 300, 480, and 600 volts, and DC voltage ratings of 60, 125, 160, 250, 300, 400, 500, and 600 volts. Fuses may be rated for AC only or DC only, or they may have both an AC and a DC voltage rating. Supplementary fuses have voltage ratings from 32 to 1,000 volts AC and/or DC.

300 volt Class T fuses (Littelfuse JLLN series) may only be used for single-phase to neutral loads where the voltage does not exceed 300 volts to ground. They may not be used in three-phase, four wire, 480/277 volt, wye systems or in 480 volt corner-grounded delta systems.

#### Interrupting Rating

A fuse's interrupting rating is the highest available symmetrical rms alternating current that the fuse is required to safely interrupt at rated voltage under standardized test conditions without being damaged. A fuse must interrupt all overcurrents up to its interrupting rating. Fuses are available with interrupting ratings of 10,000A, 50,000A, 100,000A, 200,000A, and 300,000A.

NEC Article 110.9 requires all equipment intended to break current at fault levels to have an interrupting rating sufficient for system voltage and current available at the equipment's line terminals. Refer to **Figure 10**. Select fuses with interrupting ratings which equal or exceed the available fault current.

Standardizing on fuses with at least a 200,000 ampere interrupting capacity (AIR) ensures that all fuses have an adequate interrupting

## Fuse Application Guide

### Overcurrent Protection Fundamentals

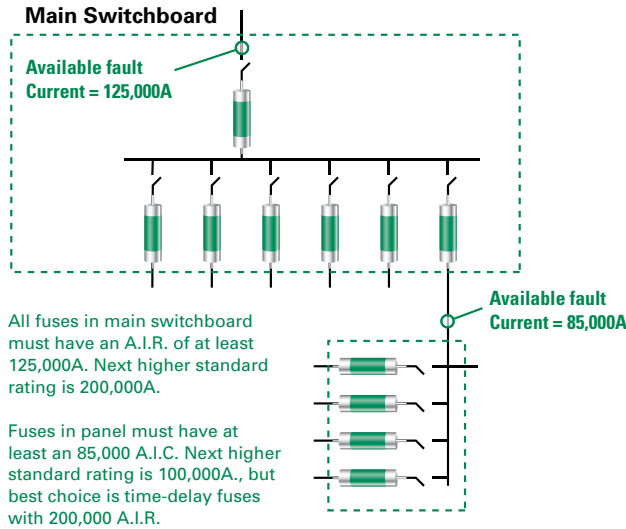

Figure 10

rating, and provides reserve interrupting capacity for future increases in available fault current.

#### 300,000 AIC Fuses

Littelfuse POWR-PRO® fuse series have a Littelfuse Self-Certified interrupting rating of 300,000 amperes rms symmetrical. The 300,000 ampere testing was performed in a Nationally Recognized Testing Laboratory, and the tests were UL witnessed. UL has ruled that fuses with a UL interrupting rating greater than 200,000 amperes must be marked as "Special Purpose Fuses" and may not be labeled as UL Listed Class RK5, RK1, L, etc.

Littelfuse feels that the "Special Purpose Fuse" classification adds confusion to specification writing for both fuses and switches and complicates fuse procurement. Since only a very small number of installations have a real need for fuses with interrupting ratings in excess of 200,000 amperes, Littelfuse will continue to UL List their fuses by UL standard fuse classes that have interrupting ratings up to 200,000 amperes. Littelfuse fuses which have passed the 300,000 ampere tests are marked on the label: "300kA (Self certified by Littelfuse)". UL listing cards showing 300,000 AIC and the special purpose classification are available on request. Refer to the product section of this catalog for information on specific fuse classes.

#### Time Current Characteristics

Time current characteristics determine how fast a fuse responds to overcurrents. All fuses have inverse time characteristics; that is, the fuse opening time decreases as the value of overcurrent increases. When properly rated in accordance with NEC requirements, fuses provide both overload and short-circuit protection to system conductors and components. However, in some instances such as when fuses are used to backup circuit breakers or to provide motor branch circuit short-circuit and ground fault protection, fuses provide only short-circuit protection. A fuse's response to overcurrents is divided into overloads and short-circuits.

#### Overloads

While fuses must disconnect overloaded conductors and equipment before the conductors and components are seriously overheated, they should not disconnect harmless temporary overloads. To provide overload protection for system conductors, UL has established maximum fuse opening times at 135% and 200% of a fuse's current rating. All UL Listed fuses for application in accordance with the National Electrical Code® (NEC®) must meet these limits whether they are fast-acting or time-delay fuses.

#### Fast-Acting (Normal-Opening) Fuses

Fast-acting fuses (sometimes called "Normal-opening fuses") have no intentional time-delay. Typical opening times at 500% of the fuse ampere rating range from 0.05 to approximately 2 seconds. Fast-Acting fuses are suitable for non-inductive loads, such as incandescent lighting and general-purpose feeders, or branch circuits with little or no motor load. When protecting motors and other inductive loads, fast-acting fuses must be rated at 200-300% of load currents to prevent nuisance opening on in-rush currents. Fuses with such increased ratings no longer furnish adequate protection from overloads. They provide only short-circuit protection. Overload relays or other overload protection must be provided to protect conductors and equipment from overload conditions.

#### Time-Delay (Dual Element) Fuses

UL Classes CC, CD, G, H, L, RK5 and RK1 fuses, plus some of the UL Listed Miscellaneous fuses, may have time-delay. If so, they are identified on the fuse label with "Time-Delay", "T-D", "D", or some other suitable marking. Minimum time-delay varies with the fuse class, and to some degree with the fuse ampere rating. UL standards for POWR-GARD™ Fuses Products series IDSR, FLNR\_ID, and FLRSR\_ID (UL Class RK5), LLNRK, LLSRK, LLSRK\_ID (UL Class RK1), and JTD, JTD\_ID (UL Class J) fuses require them to carry 500% rated current for a minimum of 10 seconds. Standards for CCMR and KLDR (UL Class CC and CD) and SLC (UL Class G) require them to carry 200% rated current for a minimum of 12 seconds.

Although there is no UL Classification for time-delay Class L fuses, they may be marked "Time-Delay." The amount of time-delay is determined by the manufacturer. POWR-PRO® KLPC series and POWR-GARD KLLU series fuses will hold 500% current for 10 seconds or more.

In addition to providing time-delay for surges and short time overloads, time-delay fuses meet all UL requirements for sustained overload protection. On higher values of current, time-delay fuses are current-limiting meaning they remove large overcurrents in less than one-half cycle (0.008 seconds). Time-delay fuses provide the best overall protection for both motor and general purpose circuits, and eliminate nuisance fuse opening and most downtime.

Compared to fast-acting fuses, time-delay fuses can be selected with ratings much closer to a circuit's operating current. For example, on most motor circuits, RK5 and RK1 fuses can be rated at 125-150% of a motor's full load current (FLA). This provides superior overload and short-circuit protection, and often permits using smaller, less expensive switches. Time-delay fuses have gradually replaced most one-time and renewable fuses. Today, more than 50% of all fuses sold by electrical distributors are time-delay fuses such as Littelfuse POWR-PRO LLSRK\_ID series fuses.

## Fuse Application Guide

### Overcurrent Protection Fundamentals

#### Very Fast-Acting Fuses

The principle use of very fast acting fuses is to protect solid-state electronic components, such as semiconductors. Their special characteristics, including quick overload response, very low  $I^2t$ ,  $I_{peak}$  and peak transient voltages provide protection for components that cannot withstand line surges, low value overloads, or short-circuit currents.

#### Short-Circuits

A fuse's short-circuit response is its opening time on higher-value currents. For power fuses, that is generally over 500 – 600% of the fuse's rating. As stated earlier, all fuses have inverse time characteristics: the higher the current, the faster the opening time. Since short-circuits should be removed quickly, inverse time is especially important for short-circuit protection.

#### Current-limiting Fuses

Current-limiting fuses must have the following characteristics:

1. Limit peak currents to values less than those which would occur if the fuses were replaced with solid conductors of the same impedance. This reduced peak current is referred to as a fuse's "Peak Let-through Current."
2. When the fault current exceeds the fuse threshold current, the fuse must open the circuit in less than 180 electrical degrees ( $1/2$  cycle) after the start of the fault.
3. Matching fuse holders and/or fuse blocks must reject non-current-limiting fuses and accept only current-limiting fuses of the stated UL Class.

#### Fast-Acting (Normal Opening) Fuses

All fast-acting fuses provide fast short-circuit response within their interrupting rating. Some are current-limiting, such as Class T and J. Others are non-current-limiting, such as Class H.

#### Dual Element (Time-delay) Fuses

Littelfuse time-delay IDSR, FLNR\_ID/FLSR\_ID Class RK5, and LLNRK/LLSRK\_ID Class RK1 series fuses have true dual-element construction. Time-delay elements are used for overload protection, and separate fast acting fuse links are used to provide current-limiting short-circuit protection.

#### Very Fast-Acting Fuses

Very fast-acting fuses are designed for very fast response to overloads and short-circuits. They are very current-limiting.

#### Understanding Time-current Curves

Time-current curves for Littelfuse POWR-GARD™ fuses are shown in each product section. They show the average melting times for that fuse series at any current. In order to make the curves more readable, they are presented on log-log paper. The overcurrent values appear at the bottom, and increase from left to right. Average melting times appear on the left-hand side of the curve and increase from bottom to top. The amperage ratings of the individual fuses for a given series are listed at the top and increase from left to right. **Figure 11** shows the average melting time curves for a typical time-delay fuse series.

**Figure 12** compares the average melting times for 100 and 600 amp ratings of three fuse types: Littelfuse POWR-GARD dual-element, time-delay LLSRK series RK1 fuses; Littelfuse normal opening NLS series fuses and Littelfuse very fast acting L60S series semiconductor fuses.

**Table 1** compares the opening times for these fuses.

#### Peak Let-through Charts

Fuses that are current-limiting open severe short-circuits within the first half-cycle (180 electrical degrees) after the fault occurs. They also reduce the peak current of the available fault current to a value less than would occur without the fuse. This is shown in **Figure 13**.

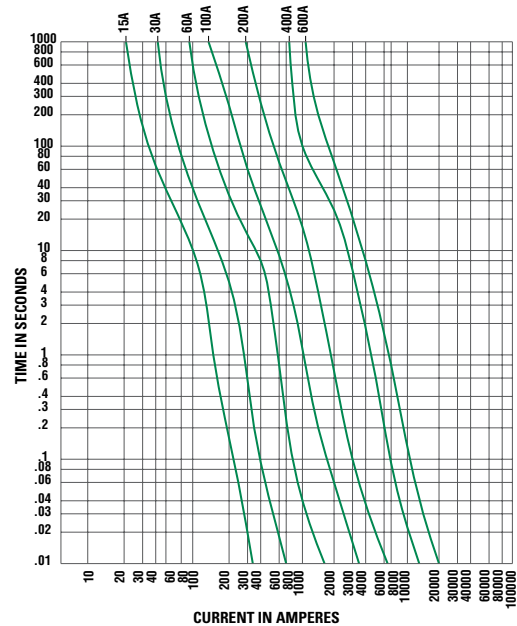

Figure 11

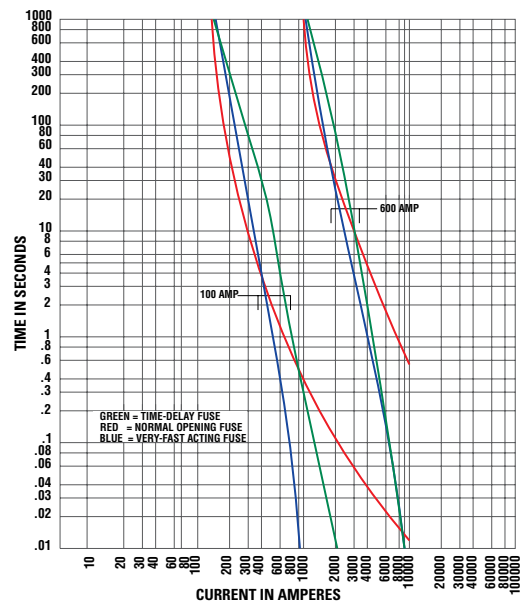

Figure 12

## Fuse Application Guide

### Overcurrent Protection Fundamentals

**Table 1**  
Comparative Opening Times for Time-Delay, Fast-Acting, and Very Fast-Acting Fuses

Ampere Rating	Fuse Type	Opening Time in Seconds		
		500% Rating	800% Rating	1200% Rating
100	Time-Delay	12 secs.	0.9 secs.	0.14 secs.
	Normal Opening	2 secs.	0.7 secs.	0.3 secs.
	Very Fast-Acting	1.3 secs.	0.02 secs.	>0.01 secs.
600	Time-Delay	14 secs.	0.7 secs.	0.045 secs.
	Normal Opening	10 secs.	3 secs.	1.1 secs.
	Very Fast-Acting	2 secs.	0.05 secs.	>0.01 secs.

A fuse current-limiting effects are shown graphically on Peak Let-through charts such as the one in **Figure 14**. The values across the chart's bottom represent the available (also referred to as potential or prospective) rms symmetrical fault current. The values on the chart's left side represent the instantaneous available peak current and the peak let-through current for various fuse ratings.

As an example, enter the chart on the bottom at 100,000 rms symmetrical amperes and read upwards to line A-B. From this point, read horizontally to the left and read an instantaneous peak current of 230,000 amperes. In a circuit with a 15% short-circuit power factor, the instantaneous peak of the available current approximates 2.3 times the rms symmetrical value. Line A-B on the chart has a 2.3:1 slope.

The curves that branch off line A-B show the current-limiting effects of different fuse ampere ratings. Enter the chart in **Figure 14** on the bottom at 100,000 rms symmetrical amperes and read upwards to the intersection of the 200 ampere fuse curve. Read horizontally to the left from this point and read approximately 20,000 amperes. The 200 ampere fuse has reduced the peak current during the fault from 230,000 amperes to 20,000 amperes. 20,000 amperes is less than one-tenth of the available current. Magnetic force created by current flow is a function of the peak current squared. If the peak let-through current of a current-limiting fuse is one-tenth of the available peak, the magnetic force is reduced to less than  $1/100$  of what would occur without the fuse.

#### Using the Peak Let-through Charts ("Up-Over-and-Down")

Peak Let-through Charts for Littelfuse POWR-GARD™ fuses are shown in each product section of this catalog. These charts are useful in determining whether a given fuse can protect a specific piece of equipment.

For example, with an available fault-current of 100,000 rms symmetrical amperes, determine whether 600 amp 250 volt time-delay Class RK1 fuses can protect equipment with a 22,000 amp short-circuit rating. Refer to **Figure 15**.

Locate 100,000A available fault-current on the bottom of the chart (Point A) and follow this value upwards to the intersection with the 600A fuse curve (Point B). Follow this point horizontally to the left to intersect with Line A-B (Point C). Read down to the bottom of the chart (Point D) and read approximately 18,000 amps.

The POWR-PRO® LLNRK 600 ampere RK1 current-limiting fuses have reduced the 100,000 amperes available current to an apparent or equivalent 18,000 amps. When protected by 600 amp LLNRK RK1 fuses, equipment with short-circuit ratings of 22,000 amps may be safely con-

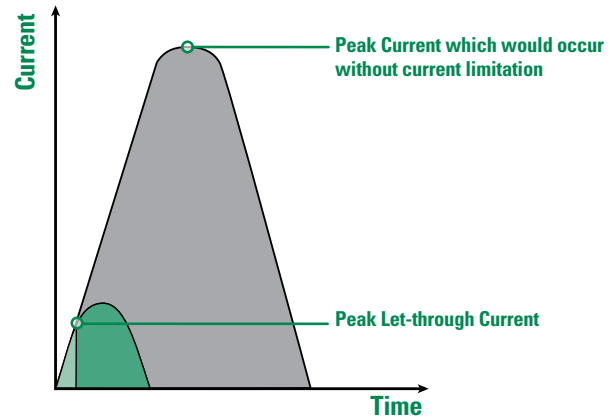

**Figure 13**  
Current limiting effect of fuses

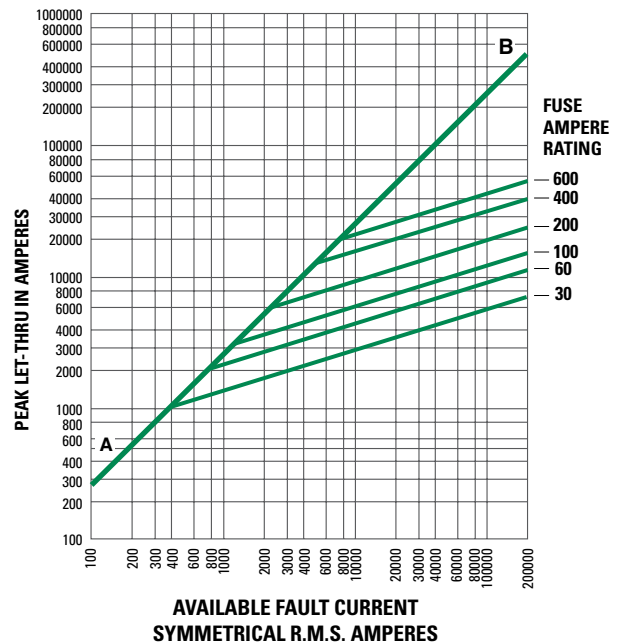

**Figure 14**  
Peak Let-through Charts

nected to a system having 100,000 available rms symmetrical amperes.

This method, sometimes referred to as the "Up-Over-and-Down" method, may be used to:

1. Provide back-up short-circuit protection to large air power circuit breakers.
2. Enable non-interrupting equipment such as bus duct to be installed in systems with available short-circuit currents greater than their short-circuit (withstand) ratings.

## Fuse Application Guide

### Overcurrent Protection Fundamentals

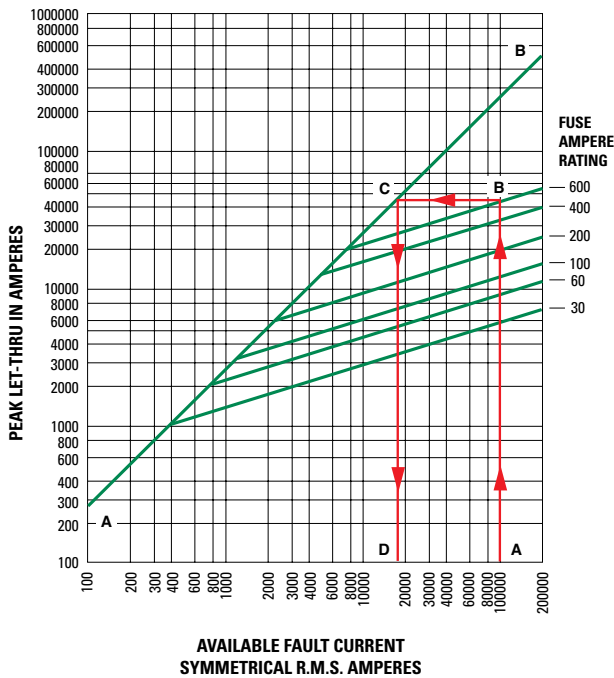

**Figure 15**  
**Peak Let-through Chart for POWR-PRO®**  
**LLNRK Class RK1 Dual-Element Fuses.**  
**Using the Up-Over-and-Down Method.**

This method **may not** be used to select fuses for backup protection of molded case or intermediate frame circuit breakers. National Electrical Code® (NEC®) Article 240.86 states:

“Where a circuit breaker is used on a circuit having an available fault current higher than its marked interrupting rating by being connected on the load side of an acceptable overcurrent protective device having the higher rating, 240.86(A) and (B) shall apply.

(A) Marking. The additional series combination interrupting rating shall be marked on the end use equipment, such as switchboards and panelboards.”

NEC Article 110.22 states:

“Where circuit breakers or fuses are applied in compliance with the series combination ratings marked on the equipment by the manufacturer, the equipment enclosure(s) shall be legibly marked in the field to indicate the equipment has been applied with a series combination rating. The marking shall be readily visible and state the following:

CAUTION - SERIES COMBINATION SYSTEM RATED \_\_\_\_\_  
 \_\_\_\_\_ AMPERES. IDENTIFIED REPLACEMENT COMPONENTS  
 REQUIRED.

UL Listed fuse-to-circuit breaker series ratings are now available from most national loadcenter and panelboard manufacturers. The Listings are shown in their product digests and catalogs. Many local builders have also obtained fuse-to-circuit breaker series ratings. For additional information on this subject contact the Littelfuse Technical Support and

Engineering Services Group at 1-800-TEC-FUSE (1-800-832-3873).

#### Ampere (Current) Rating

A fuse ampere rating is the AC or DC current that the fuse can continuously carry under specified conditions. Fuses selected for a circuit must have ampere ratings that meet NEC requirements. These NEC requirements establish maximum ratings and, in some cases, minimum ratings. NEC Articles 240 and 430 contain specific requirements.

#### Fuse Dimensions

There is a trend toward miniaturization in almost everything, and electrical equipment is no exception. While saving space may be an important factor when selecting the proper fuses, other considerations should not be overlooked. Some of these are:

- Does the smallest fuse have the most desirable characteristics for the application?
- Does the equipment in which the fuse will be installed provide adequate space for maintenance?
- Do smaller fuses coordinate well with the system's other overcurrent protection?

### General Fusing Recommendations

#### Fuse Ratings from 1/10 through 600 amperes

When available fault currents are less than 100,000 amperes and when equipment does not require the more current-limiting characteristics of RK1 fuses, POWR-PRO FLSR\_ID series Indicating Class RK5 current-limiting fuses provide superior time-delay and cycling characteristics along with all the benefits of an indicating fuse at lower cost than RK1 fuses. FLSR\_ID series fuses tell you when they have protected your circuit and need to be replaced. If available fault currents exceed 100,000 amperes, equipment may need the additional current-limitation capabilities of the POWR-PRO LLNRK/LLSRK/LLSRK\_ID series Class RK1 fuses.

Fast-acting JLLN/JLLS series Class T fuses possess space-saving features that make them especially suitable for protection of molded case circuit breakers, meter banks, and similar limited-space applications.

Time-delay JTD\_ID/JTD series Class J fuses are used in OEM motor control center applications as well as other MRO motor and transformer applications requiring space-saving IEC Type 2 protection.

Class CC and Class CD series fuses are used in control circuits and control panels where space is at a premium. Choose Littelfuse POWR-PRO CCMR series fuses for protection of small motors. They are now available with ampere ratings up to 60 amperes. Choose Littelfuse KLDR series fuses for the protection of control power transformers and similar devices.

Should you have any questions concerning product applications, call our Technical Support Group at 800 TEC FUSE.

#### Fuses with ampere ratings from 601 through 6,000 amperes

For superior protection of most general-purpose and motor circuits, we recommend POWR-PRO KLPC series Class L fuses.

## Fuse Application Guide

### Overcurrent Protection Fundamentals

#### Coordinated (Selective) Systems

A “coordinated” or “selective” system is a system whose overcurrent protective devices have been carefully chosen and their time-current characteristics coordinated. Only the overcurrent device immediately on the line side of an overcurrent will open for any overload or short-circuit condition.

See definition of Selective Coordination in Definitions, and refer to **Figure 5** for a graphical example.

When a system is not coordinated, a fault at X might cause Fuse B to open. This increases the amount of equipment out of service, and makes it more difficult to locate the problem, thereby increasing downtime.

Since the advent of electrical and electronic equipment, businesses have become entirely dependent on the continuous availability of electric energy. Loss of power halts all production. Customer service is interrupted; order processing ceases; yet expenses continue.

Even many UPS systems become unintentionally non-selective, causing power loss to computers and other critical equipment. Non-selectivity may defeat otherwise well-engineered UPS systems.

In a selective system, none of this occurs. Overloads and faults are disconnected by the overcurrent protective device immediately on the line side of the problem. Minimum equipment is removed from service, the faulted or overloaded circuit is easy to locate, and minimum time is required to restore full service.

For these and many other reasons, selectivity is the standard by which many systems are judged.

#### Fuse Selectivity

Refer to **Figure 11** which shows typical average melting time curves for one class of fuses. Note that the curves are roughly parallel, and that for a given overcurrent the smaller fuse ratings respond quicker than the larger ratings. The heat energy required to open a fuse is divided into melting  $I^2t$  and arcing  $I^2t$  (see definition of Ampere-Squared-Seconds). The sum of these is the total clearing  $I^2t$ .

For a system to be coordinated, the smaller fuse total clearing  $I^2t$  must be less than the larger fuse melting  $I^2t$ . Put another way, if the downstream (branch) fuse opens the circuit before the overcurrent affects the upstream (feeder) fuse element, the system will be selective. This can be determined from curves showing melting and total clearing  $I^2t$ , or from minimum melting and maximum clearing time-current curves.

The simplest method of coordinating low voltage power fuses is by use of a Coordination Table such as the one shown in **Table 2**. This table is only applicable for the Littelfuse POWR-PRO® and POWR-GARD™ fuse series listed. Tables such as this one greatly reduce design time. For example, the coordination table shows that POWR-PRO KLPC Class L fuses coordinate at a two-to-one ratio with other Class L fuses, and with POWR-PRO LLNRK/LLSRK/LLSRK\_ID series Class RK1 and POWR-PRO JTD/JTD\_ID series Class J fuses.

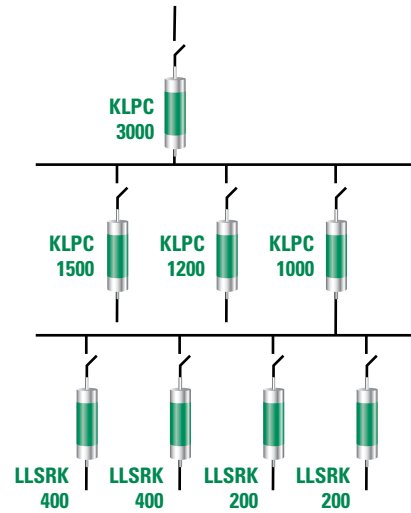

**Figure 16**  
**A Coordinated (selective) Fused System**

In the system shown in **Figure 16**, the 3000 amp Class L main fuses are at least twice the ratings of the 1500, 1200, and 1000 amp Class L feeder fuses, therefore they will coordinate. The Coordination Table also shows that the LLSRK series time-delay RK1 feeder and branch circuit fuses coordinate at a two-to-one ratio with the Class L feeder fuses, so the entire system in **Figure 16** would be 100% coordinated.

#### Circuit Breaker Coordination

Because of the many types of circuit breakers and circuit breaker trip units, developing a coordinated circuit breaker system or coordinating circuit breakers with fuses is beyond the scope of this Guide. If you have questions concerning these subjects contact the Littelfuse Technical Support Group. For more information on fuses and circuit breakers request Littelfuse Tech Topics Volume 2 – Fuses Vs. Breakers (PF327).

#### Component Short-Circuit Protecting Ability

NEC requires equipment protection to be coordinated with overcurrent protective devices and available fault current to prevent extensive damage to equipment. See **Figure 17**. Essentially, this means that electrical equipment must be capable of withstanding heavy overcurrents without damage or that they are protected by overcurrent protective devices that will limit damage.

When a severe fault occurs in an unprotected circuit, current immediately increases to a very high value. This is the available or prospective fault current. Some fuses respond so quickly to the increasing current that they interrupt current within the first half-cycle; before the current reaches its first peak. See **Figure 13**. Such fuses are termed “current-limiting fuses.” Current-limiting fuses stop damaging current faster than any other protective device. Current-limiting fuses greatly reduce or totally prevent component damage from high fault currents. This helps meet the NEC® Article 110.10 requirements shown in **Figure 17**.

# Fuse Application Guide

## Overcurrent Protection Fundamentals

**Table 2**  
Fuse Coordination Table

**Selecting the Correct Fuse Ampere Ratio to Maintain Selectively Coordinated Systems**  
Ratios are expressed as Line-Side Fuse to Load-Side Fuse

Line-Side Fuses			Load-Side Fuses									
Ampere Range	UL Class	Littelfuse Catalog No.	Time-Delay Fuses					Fast-Acting Fuses				
			Ampere Range, UL Class and Catalog No.					Ampere Range, UL Class and Catalog No.				
			601-6000	601-4000	30-600	30-600	30-600	30-600	30-1200	30-600	1-60	
			L	L	RK1	J	RK5	RK1	T	J	G	
			KLPC LDC	KLLU	LLNRK LLSRK_ID	JTD_ID JTD	FLNR_ID FLSR_ID IDSR	KLNR KLSR	JLLN JLLS	JLS	SLC	
601-6000	L	KLPC	2:1	2:1	2:1	2:1	4:1	2:1	2:1	2:1	N/A	
601-4000	L	KLLU	2:1	2:1	2:1	2:1	4:1	2:1	2:1	2:1	N/A	
601-2000	L	LDC	2:1	2:1	2:1	2:1	4:1	2:1	2:1	2:1	N/A	
30-600	RK1	LLNRK	N/A	N/A	2:1	2:1	8:1	3:1	3:1	3:1	4:1	
30-600	RK1	LLSRK_ID	N/A	N/A	2:1	2:1	8:1	3:1	3:1	3:1	4:1	
30-600	J	JTD_ID	N/A	N/A	2:1	2:1	8:1	3:1	3:1	3:1	4:1	
30-600	RK5	IDSR	N/A	N/A	1.5:1	1.5:1	2:1	1.5:1	1.5:1	1.5:1	1.5:1	
30-600	RK5	FLNR_ID	N/A	N/A	1.5:1	1.5:1	2:1	1.5:1	1.5:1	1.5:1	1.5:1	
30-600	RK5	FLSR_ID	N/A	N/A	1.5:1	1.5:1	2:1	1.5:1	1.5:1	1.5:1	1.5:1	
30-600	RK1	KLNR	N/A	N/A	3:1	3:1	8:1	3:1	3:1	3:1	4:1	
30-600	RK1	KLSR	N/A	N/A	3:1	3:1	8:1	3:1	3:1	3:1	4:1	
30-1200	T	JLLN	N/A	N/A	3:1	3:1	8:1	3:1	3:1	3:1	4:1	
30-1200	T	JLLS	N/A	N/A	3:1	3:1	8:1	3:1	3:1	3:1	4:1	
30-600	J	JLS	N/A	N/A	3:1	3:1	8:1	3:1	3:1	3:1	4:1	
1-60	G	SLC	N/A	N/A	3:1	3:1	4:1	2:1	2:1	2:1	2:1	

NATIONAL ELECTRICAL CODE®

**ARTICLE 110 – REQUIREMENTS FOR ELECTRICAL INSTALLATIONS**

**A. General**

**110-3. Examination, Identification, Installation, and Use of Equipment.**

(A) Examination. In judging equipment, considerations such as the following shall be evaluated:

(5) Heating effects under normal conditions of use and also under abnormal conditions likely to arise in service.

(6) Arcing effects.

(B) Installation and Use. Listed or labeled equipment shall be used or installed in accordance with any instructions included in the listing or labeling.

**110.9 Interrupting Rating.** Equipment intended to interrupt current at fault levels shall have an interrupting rating sufficient for the nominal circuit voltage and the current that is available at the line terminals of the equipment.

Equipment intended to interrupt current at other than fault levels shall have an interrupting rating at nominal circuit voltage sufficient for the current that must be interrupted.

**110.10 Circuit Impedance and Other Characteristics.** The overcurrent protective devices, the total impedance, the component short-circuit current ratings, and other characteristics of the circuit to be protected shall be selected and coordinated to permit the circuit-protective devices used to clear a fault to do so without extensive damage to the electrical components of the circuit. This fault shall be assumed to be either between two or more of the circuit conductors or between any circuit conductor and the grounding conductor or enclosing metal raceway. Listed products applied in accordance with their listing shall be considered to meet the requirements of this section.

**ARTICLE 240 – OVERCURRENT PROTECTION**

**240.1 Scope.** Parts I through VII of this article provide the general requirements for overcurrent protection and overcurrent protective devices not more than 600 volts, nominal. Part VIII covers overcurrent protection for those portions of supervised industrial installations operating at voltages of not more than 600 volts, nominal. Part IX covers overcurrent protection over 600 volts, nominal.

(FPN): Overcurrent protection for conductors and equipment is provided to open the circuit if the current reaches a value that will cause an excessive or dangerous temperature in conductors or conductor insulation. See also Sections 110.9 for requirements for interrupting ratings and 110.10 for requirements for protection against fault currents.

*(Reproduced by permission of NFPA)*

**Figure 17**  
National Electrical Code Requires Effective Overcurrent Protection

## Fuse Application Guide

### UL/CSA Fuse Charts

#### Fuses for Supplementary Overcurrent Protection

**Standards:** UL Standard 248-14 (formerly 198F); CSA Standard C22.2, No. 59-1. Three Classifications covered:

**Note:** Fuses may be rated for AC and/or DC when suitable for such use.

(1) **Micro fuses**

Voltage ratings: UL, 125 volts; CSA, 0-250 volts  
 Current ratings: UL, 0-10 amps; CSA, 0-60 amps  
 Interrupting rating: 50 amps rms symmetrical

(2) **Miniature fuses** (CSA classifies these as Supplemental Fuses)

Voltage ratings: UL, 125 or 250 volts; CSA, 0-600 volts  
 Current ratings: UL, 0-30 amps; CSA, 0-60 amps  
 Interrupting rating: 10,000 amps rms symmetrical

(3) **Miscellaneous Cartridge fuses** (CSA classifies these as Supplemental Fuses)

Voltage ratings: UL, 125 to 600 volts; CSA, 0-600 volts  
 Current ratings: UL, 0-30 amps; CSA, 0-60 amps  
 Interrupting ratings: 10,000, 50,000, or 100,000 amps rms symmetrical  
 Time delay (Optional); Minimum delay at 200% fuse rating:  
 5 seconds for fuses rated 3 amps or less  
 12 seconds for fuses rated more than 3 amps

**LF Series:** BLF, BLN, BLS, FLA, FLM, FLQ, KLC, KLK, KLKD (600 Volts DC)  
 NOTE: Littelfuse electronic fuses are also covered by these standards; see electronic section of this catalog, or request Electronic Designer's Guide (Publication No. EC101) for complete listing.

#### Special Purpose Fuses

There are no UL Standards covering this category of fuses. These fuses have special characteristics designed to protect special types of electrical or electronic equipment such as diodes, SCR, transistors, thyristers, capacitors, integrally fused circuit breakers, parallel cable runs, etc. Fuses may be UL Recognized for use as a component in UL Listed equipment. UL Recognized fuses are tested for characteristics such as published interrupting capacity. They are also covered by UL re-examination service.

Non-renewable  
**Voltage ratings:** to 1000 volts AC and/or DC  
**Ampere ratings:** to 6000 amperes  
**Interrupting ratings:** to 200,000 amperes

Dimensions vary widely depending on application, voltage and current ratings. Many of these fuses are extremely current limiting. When considering application of these fuses, or if you have special requirements, contact Littelfuse Technical Support Group for assistance.

**LF Series:** KLC, LA15QS, LA30QS, LA50QS, LA60QS, LA60X, LA70QS, LA100P, LA120X, LA070URD, LA130URD, L15S, L25S, L50S, L60S, L70S, JLLS 900 amp through 1200 amp

### Fuses for overcurrent and short-circuit protection of power and lighting feeders and/or branch circuits

### Current Limiting

### Non-Current Limiting

#### Plug Fuses

**Standards:** UL Standard 248-11 (formerly 198F), CSA Standard C22.2, No. 59.1  
**Voltage ratings:** 125 volts AC only  
**Current ratings:** 0-30 amps  
**Interrupting ratings:** 10,000 amps rms symmetrical. Interrupting rating need not be marked on fuse.

Two types: Edison-base and Type S

**Edison-base:** Base is same as standard light bulb. All amp ratings interchangeable. NEC permits Edison-base plug fuses to be used only as replacements for existing fuses, and only when there is no evidence of tampering or overfusing.

**Type S:** Not interchangeable with Edison-base fuses unless non-removable type S fuse adapter is installed in Edison-base fuse socket.

To prevent overfusing, adapters have three ampere ratings: 10-15, 16-20, and 21-30 amps.

**Time delay:** Fuses may be time delay, if so, they are required to hold 200% of rating for 12 seconds minimum.

Time delay plug fuses are marked T, TD, or Time Delay

**NOTE:** Plug fuses may be used where there is not more than 125 volts between conductors or more than 150 volts from any conductor to ground. This permits their use in 120/240 volts grounded, single-phase circuits.

**LF Series:** Edison-base: T00, TLO  
 Type S: S00, SLO  
 Type S Adapters: SA0

#### CLASS H

**Standards:** UL Standard 248-6 (formerly 198B), CSA Standard C22.2, No. 59.1  
 Also known as NEMA Class H, and sometimes referred to as "NEC" or "Code" fuses  
**Voltage ratings:** 250 and 600 volts, AC  
**Current ratings:** 0-600 amps  
**Interrupting ratings:** 10,000 amps rms symmetrical

Two types: one-time and renewable

Physically interchangeable with UL Classes K1 & K5;

Fits UL Class H fuseholders which will also accept K1, K5, RK5, and RK1 fuses.

Manufacturers are upgrading Class H One-time fuses to Class K5 per UL Standard 198D, See Class K fuses.

#### ONE-TIME FUSES (NON-RENEWABLE)

**Time delay:** Optional  
 Time-delay fuses must hold 500% current rating for a minimum of ten seconds

**LF Series:** NLKP

#### RENEWABLE FUSES

Only Class H fuses may be renewable. While time delay is optional, no renewable fuses meet requirements for time delay. Some renewable fuses have a moderate amount of time delay, referred to as "time lag" to differentiate from true time delay.

**LF Series:** RLN, RLS  
**Replaceable links Series:** LKN, LKS

# Fuse Application Guide

## UL/CSA Fuse Charts

### CURRENT LIMITING FUSE LABELING

Fuses which meet the requirements for current limiting fuses are required to be labeled "Current Limiting". Fuse labels must include: UL/CSA fuse class, Manufacturer's name or trademark, Current Rating, AC and/or DC voltage rating, and AC and/or DC interrupting rating. The words "Time Delay" or equivalent may also be included on the label when the fuse complies with time delay requirements of its class.

### CLASS G

**Standards:** UL Standard 248-5 (formerly 198C),  
CSA Standard C22.2, No. 106, classified as HRC1 Misc.

**Voltage rating:** 480 volts, AC

**Current ratings:** 0-60 amps

**Interrupting rating:** 100,000 amps rms symmetrical

Not interchangeable with any other UL fuse class.

Time delay optional: Minimum of 12 seconds at 200% current rating.

**LF Series:** SLC

### CLASS J

**Standards:** UL Standard 248-8 (formerly 198C),  
CSA Standard C22.2, No. 106, classified as HRC1-J

**Voltage rating:** 600 volts, AC

**Current ratings:** 0-600 amps

**Interrupting rating:** 200,000 amps rms symmetrical

Not interchangeable with any other UL fuse class

Time delay optional: Minimum of 10 seconds at 500% current rating.

**LF Series:** Time-Delay: JTD\_ID, JTD  
Fast-Acting: JLS

### CLASS L

**Standards:** UL Standard 248-10 (formerly 198C),  
CSA Standard C22.2, No. 106, classified as HRC1-L

**Voltage rating:** 600 volts, AC and/or DC

**Current ratings:** 601-6000 amps

KLPC also available 200-600A; LDC also available 150-600A

**Interrupting rating:** AC: 200,000 amps rms symmetrical  
DC: 50,000, 100,000, or 200,000 amps

Not interchangeable with any other UL fuse class

Time delay: Class L fuses may be marked "Time-Delay" although UL does not investigate time-delay characteristics of Class L fuses.

KLPC & KLLU: 10 seconds at 500% current rating.

LDC: 4 seconds at 500% current rating

**LF Series:** KLPC, KLLU, LDC

### CLASS R

**Standards:** UL Standard 248-12 (formerly 198E),  
CSA Standard C22.2, No. 106, classified as HRC1-R

**Voltage ratings:** 250 and 600 volts, AC; 125 and 300 volts DC

**Current ratings:** 0-600 amps

**Interrupting rating:** 200,000 amps rms symmetrical

**Two classes:** RK1 & RK5

Non-renewable

Time delay is optional for Class R fuses.

Fuses marked "Time Delay", "D", "TD", or similar indications of time delay are required to hold 500% current rating for a minimum of ten seconds.

Same Dimensions as UL Class H fuses, terminals modified to provide rejection feature.

Fits UL Class R fuseholders which reject non Class R fuses.

Physically interchangeable with UL Class H, NEMA Class H, and UL Classes K1 & K5 when equipment has Class H fuseholders.

### CLASS RK1

High degree of current limitation.  
Provides IEC Type 2 (no damage) protection for motor starters and control components  
Time Delay optional LLSRK\_ID Series provides visual indication of blown fuse

**LF Series:** Time Delay: LLNRK, LLSRK, LLSRK\_ID  
Fast-Acting: KLNR, KLSR

### CLASS RK5

Moderate degree of current limitation, adequate for most applications.  
Time Delay optional  
FLNR\_ID, FLSR\_ID and IDSR series provides visual indication of blown fuse.

**LF Series:** FLNR\_ID, FLSR\_ID and IDSR

### CLASS T

**Standards:** UL Standard 248-15 (formerly 198H),  
CSA Standard C22.2, No. 106, classified as HRC1-T

**Voltage ratings:** 300 and 600 volts AC, 125 and 300 volts DC

**Current ratings:** 0-1200 amps  
900 to 1200 amps UL Recognized for 600V version

**Interrupting rating:** 200,000 amps rms symmetrical

Non-renewable

Fast-Acting fuses. High degree of current limitation

Very small fuses; space-saving and non-interchangeable with any other fuse class.

**LF Series:** JLLN/JLLS

### CLASS CC/CD

**Standards:** UL Standard 248-4 (formerly 198C),  
CSA Standard C22.2, No. 106, classified as HRC1 Misc.

**Voltage rating:** 600 volts, AC

**Current ratings:** UL Class CC: 0-30 amps  
UL Class CD: 35-60 amps

**Interrupting ratings:** 200,000 amps rms symmetrical

Non-renewable

**Fuseholders:** Fit UL Class CC and CD fuseholders which reject non Class CC fuses.

Time delay optional: Minimum of 12 seconds at 200% current rating.

**LF Series:** KLKR (Fast-Acting)  
KLDR (Time-Delay for Transformers)  
CCMR (Time-Delay for Motors)

### CLASS K

**Standards:** UL Standard 248-9 (formerly 198D), No CSA Standard

**Voltage ratings:** 250 and 600 volts, AC

**Current ratings:** 0-600 amps

**Interrupting ratings:** Three permitted: 50,000, 100,000, and 200,000 amps rms sym

Non-renewable

Time delay is optional for Class K fuses.

Fuses marked "Time Delay", "D" or "TD" are required to hold 500% current rating for a minimum of ten seconds.

Same Dimensions and Physically Interchangeable with UL Class H fuses

Fits UL Class H fuseholders

Class K fuses are not permitted to be labeled Current Limiting because there is no rejection feature as required by NEC Article 240-60(B).

### CLASS K1

Same prescribed degree of current limitation as RK1 fuses when tested at 50,000 or 100,000 amps rms symmetrical.

**LF Series:**  
**Time Delay** – Use LLNRK/LLSRK  
**Fast-Acting** – Use KLNR/KLSR

### CLASS K5

Same prescribed degree of current limitation as RK5 fuses when tested at 50,000 or 100,000 amps rms symmetrical.

**LF Series:** NLN/NLS

## Fuse Application Guide

### Applying Fuses for Specific Applications

#### Fuses for Specific Applications (600 volts and Below)

<b>INDEX</b>	<b>Page</b>
<b>Protecting Service Entrance and Feeder Conductors</b> .....	<b>194</b>
<b>Motor Protection</b> .....	<b>194-198</b>
Motor Overload Protection (running overcurrent) .....	<b>195-196</b>
Motor Feeder (100% motor Load) over 600A .....	<b>197</b>
Motor Branch Circuit Protection over 600A .....	<b>197</b>
Motor Controller (Starter) Protection over 600A .....	<b>197</b>
Control Circuit Protection .....	<b>197</b>
Control Transformer Protection .....	<b>197-198</b>
<b>Protecting Branch Circuits</b> .....	<b>198</b>
<b>Transformer Protection</b> .....	<b>198</b>
Primary Fusing only .....	<b>198</b>
Primary Fusing With Secondary Fusing .....	<b>198</b>
Secondary Fusing of Transformers .....	<b>198</b>
<b>Fusing Capacitors</b> .....	<b>198</b>
<b>Lighting Fixture Protection</b> .....	<b>198</b>
Street Lighting and Other Weatherproof .....	<b>198</b>
..... Overcurrent Protection .....	<b>198</b>
<b>Cable Short-Circuit Protection</b> (Cable Limiter Application) ..	<b>199</b>
<b>Semiconductor and Solid-state Device Protection</b> .....	<b>199</b>
<b>Medium Voltage Protection</b> .....	<b>200-203</b>

#### Protecting Service Entrance and Feeder Conductors

##### 601 through 6000 amperes

Select POWR-PRO® KLPC series Class L fuses for AC circuits from 601 through 6000 amperes. The construction and operating characteristics of KLPC series fuses meet the toughest project specifications for Class L fuses:

- They provide maximum time-delay and current-limitation.
- They have a 300,000 amp interrupting rating.
- They have an "O-ring" seal to improve short-circuit performance.
- The fuse links are 99% pure silver.

If the system has DC circuits, another choice is the POWR-PRO LDC series Class L fuses for AC and DC circuits available from 601 through 2000 amperes. LDC series fuses are the only Class L fuses which are UL Listed at both 600 Volts AC and DC. When facilities have a mix of large AC and DC circuits, standardizing on LDC series for all Class L fuses should be considered. This reduces inventory and eliminates the possibility that an AC-only fuse will be used in a DC circuit.

When conductors are selected in accordance with the NEC®, recommended fuse ratings for mains and feeders with combined motor and non-motor loads are:

- 150% of the largest motor full load current plus,
- 100% of all other motors full load currents plus,
- 125% of the continuous<sup>1</sup> non-motor load plus,
- 100% of non-continuous, non-motor load.

If the largest motor has a long acceleration time requiring branch circuit protection to be increased to 175-225% of FLA, it may be necessary to increase main and feeder fuse ratings to 175-225% of the largest motor FLA plus the other current values as indicated above. However, if conductor ampacity has been increased to provide spare capacity for future loads, fuse ratings may be increased to the ampacity of the conductors.

When standard fuse ratings do not match conductor ampacities, the next larger standard fuse ratings may be used only if they are rated less than 800 amperes. If fuse ratings are over 800 amperes, the next smaller ratings must be used. In addition to all standard ampere ratings, KLPC and LDC series fuses have many additional ampere ratings. The additional ratings permit minimum downsizing of fuses, saving valuable conductor ampacity.

##### Main Services and Feeders 600 amps and less

Several fuse series may be used for main services and feeders under 600 amperes. Choices should be made on the needs of the particular facility. Some of the needs to be considered are discussed below, with recommendations for fuses that meet those needs.

The vast majority of electrical systems, especially those 600 amps and smaller, have available short-circuit currents less than 100,000 amperes. Class RK5 fuses have provided excellent protection for such circuits for many years. When fault currents exceed 100,000 amperes at the service entrance, a study should be made to determine if the additional current limitation provided by Class RK1 or Class J fuses is required.

POWR-PRO Class RK5, 600 Volt FLSR\_ID series Indicator® fuses provide superior time-delay plus substantially better current limitation than required by UL Class RK5 standards. In addition, the patented indicating window on the fuse immediately shows which fuses are blown. This can significantly reduce downtime.

POWR-PRO Class RK1, 250/600 Volt LLNRK/LLSRK/LLSRK\_ID series time-delay fuses are the fuse of choice for circuits where fault currents exceed 100,000 amperes. The LLSRK advanced design reduces short-circuit damage to full-size NEMA and sensitive IEC motor controllers, and is capable of providing Type 2 "No Damage" protection to NEMA size motor starters. Together with the KLPC series fuses, the LLNRK/LLSRK series form the foundation of the POWR-PRO Fuse system of overcurrent protection. And, the patented indicating window on the LLSRK\_ID series provides the same benefits of blown fuse indication for the user.

POWR-PRO Class J 600 Volt JTD\_ID series time-delay fuses provide the amount of time-delay necessary for most applications and are substantially smaller than RK5 or RK1 fuses with current-limitation equal to the RK1 fuse. JTD\_ID series fuses provide IEC Type 2 "No Damage" protection to both NEMA and IEC control components and motor controllers. When time-delay is required and space is the determining factor, JTD\_ID time-delay Class J fuses provide the answer.

1 See Definitions for "Continuous Load."

## Fuse Application Guide

### Applying Fuses for Specific Applications

When conductors are selected in accordance with the NEC®, recommended fuse ratings for mains and feeders rated 1 to 600A with combined motor and non-motor loads are:

- 150% of the largest motor full load current plus,
- 100% of all other motors full load currents plus,
- 125% of the continuous<sup>1</sup> non-motor load plus,
- 100% of non-continuous, non-motor load.

### Motor Protection

The importance of effective motor and motor circuit protection cannot be over emphasized. Motors are consistently the largest single cause of industrial and commercial fires.

In today's highly automated commercial and industrial facilities, the failure of even one relatively minor motor may shut down an entire installation.

#### Motor Characteristics

Motors discussed herein are standard characteristic AC induction motors, which cover about 80-85% of all motors. Special purpose motors are beyond the scope of this publication. Specific application information and protection requirements for these special purpose motors should be obtained from the motor manufacturers.

#### Horsepower Ratings

A motor's assigned horsepower rating indicates the work that it can do under standard test conditions. It is the maximum horsepower load the motor can drive over a long period without exceeding its rated temperature rise. However, a motor can develop far more horsepower than its rating, and if the overload does not last long enough to overheat the motor, no damage occurs.

A motor tries to rotate any load attached to it. If the load is too large, the motor will not be able to rotate and will overheat and fail within a very short period. However, if the motor is able to start and run with an overload, excess heat will be generated. If the motor is not stopped or the overload removed, the excess heat will gradually deteriorate the insulation, and the motor will prematurely fail.

#### Motor RPM

The motor nameplate shows the rated speed of the motor in revolutions per minute (RPM) with rated full load attached. The no-load speed of the motor is somewhat higher. The no-load (synchronous) speed of a motor is a function of its design and the number of poles (windings).

**Table 3** shows the relationship between the number of poles, no-load speed, and full load speed shown on the motor nameplate.

**Table 3**

**Synchronous (No Load) Speed of Induction Motors vs Full Load Speed**

Number of Poles	Synchronous (No Load) Speed (RPM)	Typical Full Load Speed Range (RPM)
2	3600	3450 – 3500
4	1800	1710 – 1760
8	900	855 – 880
12	600	520 – 610

All non-synchronous induction motors begin to slow down as the load increases. This is commonly referred to as "slip." As load increases, the motor current and slip increase.

#### Motor Running Current

**Full Load Amperes (FLA or F.L.A.):** A motor's rated full load amps (full load current) is the motor's running current when connected to a load equal to its horsepower rating. If load exceeds the horsepower rating, current will exceed the FLA and the motor may overheat. The vast majority of motors are only partially loaded. As load decreases, motor current decreases.

**Partially Loaded Motors:** If a motor is not connected to any external load, it still requires a certain amount of current to turn the rotor. This is defined as the "no-load amps" or "no-load current." No-load current is a constant for any given motor and does not change with load. However, no-load current varies widely for different motor designs and horsepower ratings.

A motor's actual running current is the sum of no-load current and load current. For all practical purposes, load current increases directly as the load increases. If a motor is loaded to only 50% of rated horsepower, then the actual load current will be approximately 50% of the full potential load current.

If a given motor's no-load current is 30% of FLA, load current is 70% FLA (100% - 30% = 70%). At 50% rated load, the load current would be about 35% FLA (one-half of 70%). Added to no-load current of 30%, motor running current at 50% load will be about 65% FLA (30 + 35 = 65%). If the same motor were 75% loaded, the motor running current would be about 83% FLA (0.70 X 0.75 + 0.30 = 0.83).

**Motor starting currents:** When a motor is first energized, a great deal of energy (torque) is required to overcome the inertia of the motor and the load. Once the load is moving, it requires much less energy to keep it moving.

At the instant a motor is energized, motor current peaks at about 12-15 times the nameplate FLA. This is the current required to magnetize the motor windings. Within 1/2 to 3/4 cycles (0.008-0.0125 seconds) the full magnetic field is developed, and current decreases from 12 to 15 times FLA to roughly 4.5 to 8 times FLA. This is called the motor starting current, and is also the current the motor will draw if it stops while energized. This is why it is also referred to as the locked-rotor amps (LRA).

The exact value of LRA is determined by motor design, and is shown on the motor nameplate by the NEMA design letter. Motors designed to start only low inertia loads have the lowest starting current. Motors with the same horsepower ratings but designed to start very high inertia loads such as large flywheels, hammer mills, etc., will have much higher starting currents. **Table 4** shows the starting current for various designs.

As the motor speed increases from zero, current remains high until the motor reaches about 85-90% full speed. Current then begins to decrease, and when the motor reaches full speed for the attached load, current decreases to normal running current.

## Fuse Application Guide

### Applying Fuses for Specific Applications

**Table 4**

**Starting Current (Amperes) for Various Types of Motor Designs**

NEMA Code Letter	Locked Rotor KVA Per Hrspwr.	Maximum Locked Rotor Amps for NEMA Code Letter Motors					
		Single Phase		Three Phase			
		115V	230V	200V	230V	460V	575V
A	3.14	27.3	13.7	9.1	7.9	4.0	3.1
B	3.54	30.8	15.4	10.2	8.9	4.5	3.5
C	3.99	34.7	17.4	11.5	10.0	5.0	4.0
D	4.49	39.1	19.5	13.0	11.3	5.7	4.5
E	4.99	43.4	21.7	14.4	12.5	6.3	5.0
F	5.59	48.6	24.3	16.2	14.0	7.0	5.6
G	6.29	54.7	27.4	18.2	15.8	7.9	6.3
H	7.09	61.7	30.8	20.5	17.8	8.9	7.1
J	7.99	69.5	34.8	23.1	20.1	10.1	8.0
K	8.99	78.2	39.1	26.0	22.6	11.3	9.0
L	9.99	86.9	43.5	28.9	25.1	12.6	10.0
M	11.19	97.4	48.7	32.3	28.1	14.1	11.2
N	12.49	108.7	54.3	36.1	31.3	15.7	12.5
P	13.99	121.7	60.9	40.4	35.1	17.6	14.0
R	15.99	139.1	69.6	46.2	40.1	20.1	16.0
S	17.99	156.5	78.3	52.0	45.2	22.7	18.0
T	19.99	173.9	87.0	57.8	50.2	25.2	20.0
U	22.39	194.8	97.4	64.7	56.2	28.2	22.4
V	24.00	208.8	104.4	69.4	60.2	30.2	24.0

#### Single-phasing of three-phase motors

Three phase motors are designed to operate with three balanced phases. When one phase is missing, severe damage may occur if the motor is not rapidly de-energized. This may be due to an open wire in a motor junction box, an open motor winding, a blown fuse, a burned contact in a motor controller, a defective circuit breaker, or other conditions. What happens when single-phasing occurs depends on the nature of the circuit. There are several possibilities which must be examined to fully understand the problem:

#### When there is only one motor on a circuit which is single-phased

If the motor is not running at the time, and then tries to start while single-phased, it will not have sufficient available energy to overcome starting inertia, and will stay in a locked rotor condition. The motor will draw full locked rotor current, and most overcurrent protection devices will open the circuit quick enough to prevent serious motor damage.

If the motor is running at the time it is single-phased, current in the remaining legs theoretically increases to 1.73 times the current being drawn when the single-phasing occurs. Single-phased motors, however, do not have the capability of developing full horsepower and torque, so the motors may begin to slow down (increased slip) depending on the amount of load. The motor is designed to operate at full speed, so the current increases as the slip increases.

A motor that is more than 80% fully loaded at the time of single-phasing will slow down quite rapidly and stop. Current increases to locked rotor values, and the running overcurrent protection will de-energize the circuit in sufficient time to protect the motor from significant damage.

A motor that is loaded to less than 50-60% load will not slow down significantly while the current increases to 173% of the current being drawn just prior to single-phasing. Since this is less than FLA, ordinary running overcurrent protection will not sense this as an abnormal condition and the motor will continue to run. When it stops, it will obviously not restart again until the source of the single-phasing is eliminated. Fortunately, the extra heat generated under these single-phase conditions can usually be dissipated by the motor. Little damage is done, unless the single-phasing continues for an extended period of time. For added protection to large, expensive motors, (especially those over 600 volts), consideration should be given to installation of single-phase detection or voltage imbalance relays.

It is the group of motors loaded from 55-60% through 80% that present the greatest challenge. When these motors are single-phased, they slow down but continue to rotate. Current in the energized legs increases to approximately 200-220% of current being drawn at the time the motor was single-phased. This is a combination of the increase due to single-phasing (173%) plus that due to slow down (slip increase).

Since this may vary from slightly less than FLA, up to as much as 200% FLA, standard overcurrent protection may not provide adequate protection when sized in accordance with rated full load amps of the motor.

The voltage imbalance in the circuit may also result in extra heat. This additional heat produces damage in excess of that produced by current alone.

The best way of reducing this type of damage is to measure the actual current drawn by the motor under normal conditions, determine if there may be temporary overloads that need to be considered, and size overcurrent protection just large enough to permit the motor to run under normal conditions.

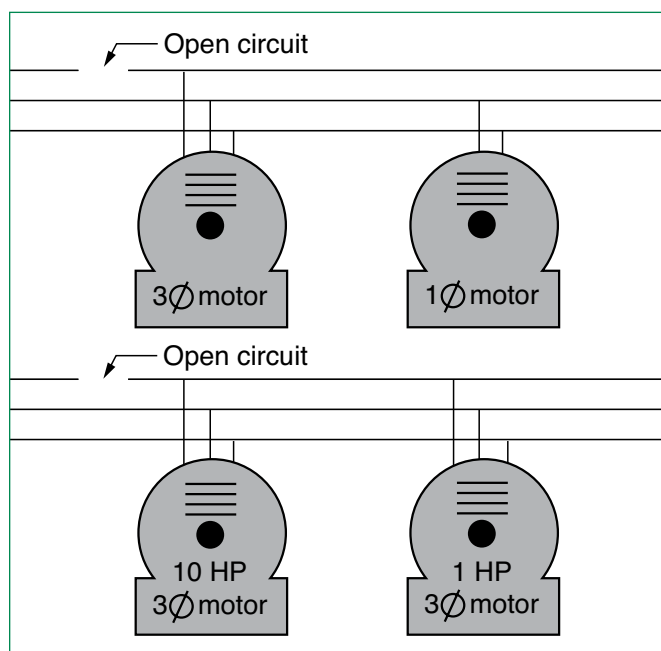

**Figure 18**

## Fuse Application Guide

### Applying Fuses for Specific Applications

#### **Several motors single-phased on one circuit**

When there is more than one motor on a circuit that is single-phased, the effects on motor current depend on the relative size of the motors, and whether they are all three-phase, or whether there is a mix of three-phase and single-phase motors.

**Figure 18** presents two such cases. In the circuit with a three-phase and a single-phase motor, the three-phase motor was loaded to 70% of full load. The feeder was then single-phased as shown. The currents in the three-phase motor increased to 52%, 120%, and 36% of full load current in the three phases. At 120% current, it is questionable whether standard running overcurrent protection sized at 115% of rated FLA could provide protection from damage due to overload and voltage imbalance.

When the circuit with the ten horsepower and one horsepower three-phase motors was single-phased, the smaller motor did little to affect the currents in the larger motor, but the one horsepower motor was in serious trouble. One of the currents was 140% of normal, while the other two currents were only slightly above the standard rating of running overcurrent protection.

When the ampere rating of a motor's running overcurrent protection is based on the motor's actual running current, adequate protection may be provided for such conditions. However, as is usually the case, if the ampere rating of a motor's running overcurrent protection is based on nameplate FLA and the motor is only partially loaded, the protective devices (overload relays and fuses) may not open in time to protect the motor because the current will not increase enough to operate the relays.

For these reasons, and many others, it is strongly recommended that Littelfuse POWR-GARD™ dual-element fuses be properly sized per the recommended guidelines.

#### **Protection required by motors**

Since mains and feeders usually serve a mix of inductive and resistive loads, time-delay fuses provide significant advantages. Even when there is no motor load, time-delay fuses reduce other nuisance outages caused by temporary overloads or switching surges. Available short-circuit current is generally highest at the main service disconnect so that adequate interrupting capacity and maximum current limitation are also desirable.

#### **Motor Branch Circuits**

Most motor circuits contain motor controllers (starters) which start and stop the motor, overload relays to provide motor running protection, and in some cases other relays to provide other types of protection.

Time-delay fuses should be considered a must for motor branch circuits. Motor starting currents and the possibility of temporary overloads and/or voltage surges would require oversizing of *non-time delay* fuses — often as much as 300%. In such cases, only short-circuit protection is provided, and because of the oversizing necessary, larger switches and enclosures are required. This is true of MCCs as well. Properly selected, time-delay fuses also provide back-up protection to the motor controllers for such conditions as single-phasing and contact welding.

Recommended ratings of RK1 and RK5 time-delay fuses for motor branch circuits containing motor controllers with overload relays are as follows:

For general purpose motors with 1.15 service factor or 40°C rise, the fuses may generally be rated at 125% of motor's FLA. When fuse ratings do not match the motor's FLA, use the next larger standard fuse rating, but do not exceed the NEC® limitation of 175% of motor's FLA as given in NEC Tables 430.248 through 430.250. Following these guidelines will provide optimum protection to the circuit.

High efficiency motors and NEMA Design E motors have much higher efficiencies, and also require higher locked rotor currents in relation to FLA. They will require careful selection of both fuses and overload relays. In these circuits, we recommend sizing fuses at 150% of FLA, or the next smaller rating.

These recommendations will cover about 90% of all motor applications. For those motors with especially severe starting duty and long acceleration times, Table 430.52 of the NEC permits time-delay fuses to be sized up to 175% of motor FLA.

If 175% of FLA will not permit the motor to start, fuse rating may be increased to a maximum of 225% of motor FLA.

Pages 204 – 206 contain Motor Protection Tables that simplify the selection of Littelfuse RK5, RK1, J and CC fuses for motor running protection and motor branch short-circuit and ground fault protection.

#### **Motor Feeders Over 600A With 100% Motor Load**

Recommended fuses are POWR-PRO® KLPC series. Recommended fuse ratings when conductors are selected in accordance with the NEC are 150% of largest motor's full load current plus the full load current of the other motors. If required rating does not correspond with a KLPC ampere rating, use the next larger rating.

#### **Fuses for Mains and Feeders With No Motor Loads**

Minimum fuse rating is 125% of the continuous load plus 100% of the non-continuous load.

#### **Fusing Motor Control Centers (MCCs)**

The same general considerations apply to protecting MCCs as they do to mains and feeders. Use time-delay current-limiting fuses as described above to provide protection to the entire MCC including buses and internal construction.

Feeders serving MCC are sized the same as general-purpose mains and feeders since many MCC have both motor and non-motor loads. Non-motor loads may include fused switches that serve dry-type power transformers used for lighting panels or feeders to distribution panels. MCC ampere ratings based on the MCC main buses usually exceed the load connected to the MCC. Therefore, fuses feeding the MCC or located in a main switch in the MCC may be rated to protect the MCC buses, as long as they meet the minimum size as determined above.

#### **Fusing Control Transformers**

With one exception, control transformers are protected the same as regular transformers as discussed below. Control transformers with primary current less than 2 amperes and which are part of a Listed motor controller may have primary fusing not greater than 500% of rated primary current.

## Fuse Application Guide

### Applying Fuses for Specific Applications

#### Protecting Branch Circuits

Multi-outlet branch circuits must be protected in accordance with the ampere rating of the overcurrent protective device. Ratings shall be 15, 20, 30, 40, and 50 amperes, although non-lighting loads in industrial facilities with adequate maintenance may have branch circuits larger than 50 amperes.

Special purpose branch circuits must have adequate capacity for the load to be served. Refer to NEC® Article 210.2 for a listing of Articles and Sections covering requirements for specific equipment not covered in this section.

#### Transformer Protection

##### Transformers over 600 volts

The basic rule for transformers rated over 600 volts requires them to have primary and secondary protection in accordance with **Table 5**.

##### Transformers rated 600 volts and less

UL Industrial Control Standards (No. 508) and Motor Control Center Standards (No. 845) specify control power transformer protection corresponding to NEC 430.72(C). In addition, UL requires the primary of control power transformers used in controllers having short-circuit ratings in excess of 10,000 amperes to be protected by UL Class CC, J, R, or T fuses. For maximum fuse ratings permitted by the NEC, refer to **Table 6** for sizing of primary fusing and **Table 7** for sizing of secondary fusing.

#### Fusing Capacitors

Capacitors installed on the load side of motor running overcurrent protection are required to have individual protection. All other capacitors are required to have an individual fuse in each ungrounded conductor. NEC Article 460.8(B) requires that the fuse rating be as small as possible. Use POWR-PRO® dual-element time-delay fuses rated at 150% to 175% of capacitor rated current.

#### Lighting Fixture Ballasts

Ballasts for all types of discharge lighting should be protected with individual fuses. Even the newer electronic ballasts with internal fusing benefit from fusing of the fixture. Individual fusing helps prevent loss of an entire lighting circuit when one ballast or fixture fails. This prevents loss of production. When only one fixture is removed from service, the user can now identify the fixture in trouble and eliminate the need to test all the fixtures to locate the problem. UL Listed Class P ballasts are only tested at 200 amps fault current, and the test circuit has a fuse ahead of the ballast. With available currents continuing to increase, individual fixture fusing reduces the possibility of the ballast failing in such a way that the fixture is damaged. Since ballast designs and characteristics vary so much, recommendations for ballast fusing should be obtained directly from the ballast manufacturer.

#### Fusing of Outdoor Lighting Standards

Whether the lighting fixtures are being used for highway lighting, street lighting, or for parking lots, each fixture should be fused using a Littelfuse Class CC or midget fuse installed in a LEB or LEC weather proof fuseholder. These fuseholders were designed to fit in the base

**Table 5**

**Fuses for Transformers over 600 volts**

Transformer Rated Impedance	Maximum Fuse Rating in Percent of Transformer Rated Current			
	Primary Fuse Rating Over 600 Volts	Secondary Fuse Rating		
		Over 600 volts in all locations	600 volts or less in unsupervised locations	600 volts or less in supervised locations
Not more than 6%	300%	250%	125%	250%
More than 6% and not more than 10%	300%	225%	125%	250%

#### Notes to Table 5

- Littelfuse IDSR, LLNRK/LLSRK/LLSRK\_ID, FLNR\_ID/FLSR\_ID, and JTD\_ID series time-delay fuses may be rated at 125% of transformer secondary current.
- Where the required fuse rating does not correspond to a standard fuse rating, the next higher standard rating is permitted.
- An individual primary fuse is not required if the primary circuit fuse is not greater than 300% of transformer primary current.

**Table 6**

**Maximum Acceptable Rating of Primary Overcurrent Device**

Rated Primary Current Amperes	Maximum Rating of Overcurrent Protective Device % of Transformer Primary Current Rating	
	No secondary fusing provided	Secondary fusing provided in accordance with Table 7
Less than 2	300 <sup>1</sup>	250 <sup>1</sup>
2 to less than 9	167	250
9 or more	125 <sup>2</sup>	250

**Table 7**

**Maximum Acceptable Rating of Secondary Overcurrent Device**

Rated Secondary Current Amperes	Maximum Rating of Overcurrent Protective Device % of Transformer Secondary Current Rating	
less than 9	167	
9 or more	125 <sup>2</sup>	

#### Notes to Tables 6 & 7

- 500% for Motor Circuit Control Power Transformers.
  - If 125% does not correspond to a standard fuse rating, the next higher standard rating may be used.
- Reference NEC 430.72 (c) Exception No. 2: 450.3 (b) 1 and 2 UL 508 32.7: 845 11.16 and 11.17.

of lighting standards. They withstand wet and corrosive conditions, including those caused by snow-melting chemicals. Fusing each fixture eliminates having to test the entire circuit for the faulted fixture when only one fails. In industrial plants where outdoor lighting provides safety and security, this is particularly important.

## Fuse Application Guide

### Applying Fuses for Specific Applications

#### Cable Short-Circuit Protection (application of cable limiters)

Cable limiters are fusible devices that provide very fast short-circuit protection, primarily to faulted cables, but also to other conductors such as busway. Cable limiters do not have an ampere rating, and cannot be used to provide overload protection. Cable limiters are selected by cable size; for example, a 500 kcmil cable requires a 500 kcmil cable limiter. Their main use is to isolate faulted cables in circuits containing three or more parallel conductors per phase and may be installed on the line side of the main service to provide short-circuit protection to the service conductors. This is especially important when service conductors are tapped from large low voltage networks or from large low impedance transformers.

The principle involved is illustrated in **Figures 19 and 20**. The first example has two cables per phase, as shown in **Figure 19**. When a fault occurs in either cable as illustrated by the "X", most of the fault current will flow directly to the fault through limiter L-1. L-1 will open, and all the fault current will back feed the fault via limiters L-3, L-4, and L-2. Since all of the limiters have the same rating, they will all open resulting in the entire circuit being shut down.

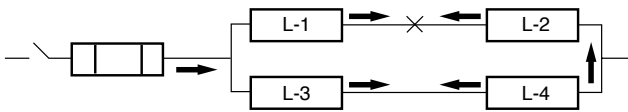

**Figure 19**

**One Line Diagram of Circuit with Two Conductors Per Phase**

However, when a fault occurs and there are three or more cables per phase, this problem can be avoided. This scenario is illustrated in **Figure 20**. When a fault occurs at point "X", current will flow directly to the fault opening limiter L-1. The fault current will back feed the fault, but when there are three or more conductors in parallel, it divides between the remaining cables. When there are three conductors in parallel as shown in **Figure 20**, one half of the fault current will flow through limiters L-3 and L-4, and one-half will flow through limiters L-5 and L-6. All of the fault current will flow through limiter L-2 causing it to open before the other limiters. As a result, only the one cable is removed from service.

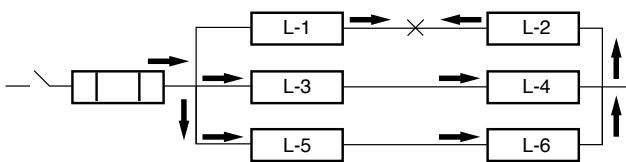

**Figure 20**

**One Line Diagram of Circuit with Three or More Conductors Per Phase**

By isolating faulted cables quickly, cable limiters prevent damage to conductor insulation caused by the heating effects of large fault currents. For example, if the cable run shown in **Figure 20** passed through pull boxes or manholes, and one section of the cable faulted, only the faulted section would require replacement instead of one or more entire lengths.

Cable limiters have terminals which permit them to be installed in a variety of equipment. The most common configuration is the offset blade on one end and the crimp terminal on the other end. This permits the limiter to replace a cable terminal (lug).

#### Applications

- Service entrance conductors.
- Between transformer or network bus and busway terminal boxes.
- Large feeders with three or more conductors per phase.

#### Features/Benefits

- Fast-acting current-limiting characteristics provide protection to conductor insulation and reduce damage when faults occur.
- Properly applied cable limiters may permit the use of equipment with reduced withstand ratings.
- Wide variety of terminations and cable ratings permit use in almost every situation.

#### Semiconductors and Solid-State Device Protection

Semiconductors generally are very sensitive to low value overloads and to short-circuit currents. As a result, they require fuses referred to as "very fast-acting" fuses. Littelfuse Semiconductor fuses are designed specifically to protect power electronics equipment. For application information refer to Littelfuse Semiconductor Application Guide PF336 or the Semiconductor fuse section of this catalog.

#### Effect Of Ambient Temperature On Fuses

The current carrying capacity of fuses is 110% of the fuse rating when installed in a standard UL test circuit and tested in open air at 25°C ambient. This allows for derating to 100% of rating in an enclosure at 40°C ambient. At higher ambient temperatures, the continuous current carrying capacity will be decreased as shown in the chart below. This closely follows the derating tables for all electrical equipment, and can help reduce equipment burnout due to high ambient conditions. Littelfuse SLO-BLO® or Time-Delay fuses derate quicker in higher ambient conditions, so they in effect, act as "self-protecting" devices and maintain their integrity until opening.

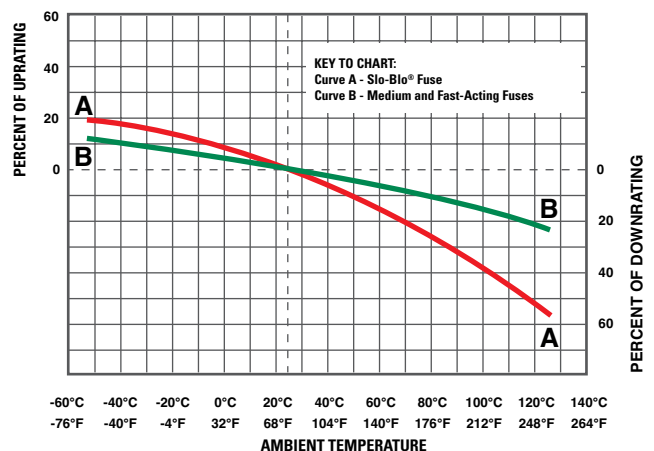

**Fuse Derating Curve**

## Fuse Application Guide

### Applying Fuses for Specific Applications/Applying Medium Voltage Fuses

## Medium Voltage (MV) Fuse Application (2,400 - 38,000 Volts AC)

Medium voltage fuses are applied quite differently than fuses rated 600 volts and less. The biggest difference is: medium voltage fuses are not intended to provide overload protection. They should only be applied where they will not be required to open small overcurrents. Another major difference is the wide range of system voltages which results in a correspondingly large number of fuse voltage ratings.

Descriptions and ratings of Littelfuse medium voltage fuses are located in the medium voltage fuse section of this catalog, which also contains some application data. The following is a more detailed discussion of factors which must be considered.

Littelfuse medium voltage fuses are silver-sand, non-expulsion, current-limiting type. When properly applied, they are designed to carry their nominal current rating continuously without "fatigue failure." This means that the fuse will not age, become brittle, or deteriorate under the most severe duty cycling.

There are two basic types of current-limiting, medium voltage fuses: general purpose and back-up. General purpose fuses have the ability to interrupt both large and small short-circuits down to currents which would cause the fuse to open within one hour. General purpose fuses are used to provide short-circuit protection for transformers, switchgear, and similar equipment.

Back-up fuses are designed to only protect against high fault currents and must be used in series with equipment which provides the circuit's required overload and low value short-circuit protection.

Medium Voltage "E" rated fuses are general purpose fuses. Their mounting dimensions permit them to be installed in a wide variety of medium voltage switches, in pad-mounted transformers, and other similar locations. "R" rated MV fuses are specifically designed to provide short-circuit protection for medium voltage motor controllers and associated equipment.

### Selecting Medium Voltage Fuses

Four factors must be considered when applying MV fuses: voltage rating, interrupting rating, current rating, and coordination with other overcurrent protective devices.

#### Voltage Rating

In common with fuses rated 600 volts and less, MV fuses minimum voltage ratings must be equal to or greater than the maximum recovery voltage which the fuse will experience under the worst possible conditions. Normally, this requires the fuse voltage rating to be greater than the system's maximum line-to-line voltage. However, when fusing single-phase loads which are connected from line-to-neutral on an effectively grounded four wire wye system, a fuse maximum design voltage only needs to be greater than the system's maximum line-to-neutral voltage. When fuses are selected on this basis, it must be impossible for the fuse to experience line-to-line voltage. Therefore, if more than one phase is extended beyond the fuse location, it is best to use fuses with a voltage rating greater than the maximum line-to-line voltage.

While not required for low voltage fuses, MV fuses maximum voltage rating must also be considered. For a fuse to be current-limiting, it must interrupt the circuit within 180 electrical degrees (one-half cycle) after the fault occurs. It does this by producing an arc voltage across the fuse which is greater than the system voltage. This forces current to zero before the available short-circuit current reaches its first peak.

Arc voltages are created in the fuse by the melting of the fuse links. This produces a number of high resistance arcs (gaps) in series, and there is a voltage drop across each gap. When the total voltage drop exceeds system voltage, current flow stops. As this occurs, a transient voltage spike is generated in the system, (**see Figure 21**). Care must be taken to see that this voltage is not greater than the system's basic insulation level (BIL). If the fuse maximum design voltage rating does not exceed 140% of the electrical system's voltage, arc (transient) voltage will not usually be a problem.

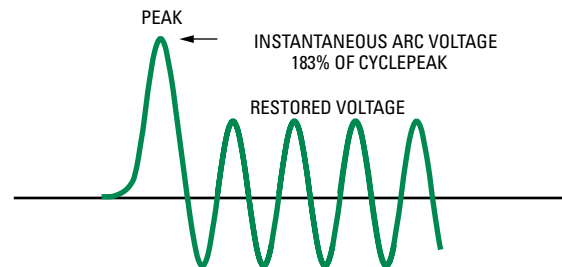

Figure 21

However, higher voltage fuses may be used if certain conditions are met. When tested at nominal voltage rating and rated interrupting current, Littelfuse MV fuses are designed so that the peak arc voltage does not exceed three times the fuse nominal voltage. If the electrical system being protected has a basic insulation level (BIL) greater than three times the fuse maximum design voltage, the higher voltage fuses may be used. See the following example:

Given: System nominal voltage = 4,800 volts  
System BIL = 50 kV

Can a POWR-GARD™ 15NLE-80E fuse, rated 14,400 volts nominal and 15,500 volts max. be used in this system?

Maximum peak voltage produced by this fuse =  
 $3 \times 14,400 = 43,200$  volts.

43,200 volts is less than the BIL of 50 kV, so the 15NLE-80E fuse may be used.

#### Medium Voltage Fuses Used With Lightning Arresters

When MV fuses are in the same circuit with lightning arresters, some precautions must be taken to insure that the transient voltage spike, which occurs when the fuse is interrupting a fault, does not cause lightning arresters to spark over. When checking the BIL of the system,

## Fuse Application Guide

### Applying Medium Voltage Fuses

#### Medium Voltage Fuses Used With Lightning Arresters

(continued from previous page)

lightning arresters are the first things that should be investigated. The lightning arrester spark-over voltage must be higher than the transient voltages which can be produced by the MV fuses. If arc voltages produced by the fuses cause lightning arresters to spark over, a relatively high current will be shunted into the arresters. However, they are not designed to interrupt such currents.

If the fuses have a voltage rating higher than the arrester and are installed on the arrester's load side, the arrester may spark over when the fuse is interrupting a large fault. If the system has only distribution class arresters, there will seldom be a problem because distribution class arresters have sufficient impedance to prevent large amounts of current from passing through them. However, intermediate, line, and station type arresters have low impedance, and if they spark over, sufficient current may flow in an arrester to damage it severely. Intermediate, line, and station type arresters should not be applied on the line side or in parallel with current-limiting MV fuses unless the arresters' spark over voltages are greater than the arc voltages the fuses can produce. If the lightning arresters and the fuses have the same voltage rating, arc voltages will be within desired limits, and the problem is eliminated.

Another approach is to locate the fuses on the line side of the arresters. However, in many cases this is impossible. Utilities prefer to locate fuses on the load side of lightning arresters to prevent lightning from damaging the fuses. In still other cases, fuses may be mounted on the primary transformer bushings or within pad-mounted transformer enclosures so that lightning arresters will be on the line side of the fuses.

Machine protection lightning arresters, such as those used to protect large motors and motor control, have very low spark over values and may be easily damaged if they are located on the fuses line side. However, arresters should always be mounted directly on the machine terminals placing them on the load side of the fuses.

#### Interrupting Ratings

Maximum rms symmetrical AC component and maximum asymmetrical current interrupting ratings for Littelfuse MV power fuses are shown in the medium voltage fuse section of this catalog. MV fuses are tested with a short-circuit X/R ratio of 25:1 which produces an rms asymmetrical multiplier of 1.6 times the symmetrical component  $\frac{1}{2}$  cycle after the fault occurs. It also produces an instantaneous asymmetrical peak current 2.66 times the rms symmetrical component. The interrupting ratings indicate the maximum symmetrical and asymmetrical fault current permitted at the point where the fuse is installed.

#### Short-circuit kVA Ratings

It is common to state the short-circuit ratings of MV breakers and other equipment such as switchgear in terms of short-circuit kVA. It must be remembered that MV power fuses are not constant kVA devices. For example, if the voltage is half of the fuse rating, the interrupting capacity does not double. MV fuse interrupting ratings are given in symmetrical and asymmetrical amperes. These values must not be exceeded at any voltage.

When the short-circuit kVA is known, the rms symmetrical AC component may be determined from the formula:

$$I_{sc} = \frac{kVA \times 1000}{1.732 \times E}$$

$I_{sc}$  = RMS symmetrical short-circuit current  
 kVA = Three phase short-circuit kVA  
 E = System line-to-line voltage

#### Effect of Frequency and Altitude

Interrupting ratings of MV fuses shown in the Product section are valid for 50 and 60 Hertz systems. For 25 Hertz systems, multiply the interrupting ratings shown by a factor of 0.74.

The continuous current ratings and interrupting ratings of MV fuses shown in the Product section are valid up to 3,000 feet. Since the density of air and its dielectric strength decreases as altitude increases, continuous current ratings and interrupting ratings are affected at altitudes exceeding 3,000 feet. **Table 8** provides altitude correction factors.

**Table 8**  
**Altitude Correction Factors per ANSI C37.40-2.3**

Altitude Above Sea Level		Continuous Current Multiplier	Interrupting Rating Multiplier
Feet	Meters		
4000	1200	.99	.98
6000	1800	.98	.92
8000	2400	.97	.86
10000	3000	.96	.80
12000	3600	.95	.75
14000	4300	.93	.70
16000	4900	.92	.65
18000	5500	.91	.61
20000	6100	.90	.56

#### Continuous Current Ratings

Available current ratings of "E-rated" and "R-rated" MV fuses are shown in the MV fuse section of this catalog. The current ratings for MV fuses carry a different meaning than ratings for 600 volt and below fuses. MV fuses are not intended to provide protection against overloads or other overcurrents less than two times their continuous current rating. If MV fuses are exposed to currents only slightly over their continuous current rating, a large amount of heat is generated within the fuse. The heat may cause the fuse tube to char and weaken, and the time-current characteristics may be changed. If circuits can produce sustained currents that are 100% to 200% of MV fuses current ratings, other overcurrent devices must be in series with the fuses to provide overload protection.

MV fuses are designed to carry their rated current without exceeding the temperature rise permitted by NEMA and ANSI standards. The "E" and "R" ratings help define the operating characteristics of the fuses:

NEMA Standards for "E-rated" MV power fuses require that fuses rated 100E or less open within 300 seconds (5 minutes) when subjected to an rms current of 200-240% of the fuse's continuous current rating. Fuses with an "E" rating larger than 100E must open within 600 seconds (10 minutes) when subjected to an RMS current of 220-264% of the fuse continuous current rating.

## Fuse Application Guide

### Applying Medium Voltage Fuses

NEMA Standards for “R-rated” MV power fuses require that they open within 15-35 seconds when subjected to an rms current 100 times the “R” rating.

These values establish one point on the fuses time-current curves and help define the characteristics of E-and R-rated fuses. Since all E and R-rated fuses must meet these requirements, the time-current characteristics of E-rated and R-rated fuses of different manufactures will have a certain similarity, although they are not necessarily identical.

A long-standing rule of thumb for applying MV fuses states that the minimum fuse rating should be at least 1.4 times the circuit’s full load current. This generally insures that MV fuses will not be required to open overloads. If the nature of the load is such that load currents will never exceed the rating of the fuse, MV fuses may be rated as close as 1.1 times full load current.

### Motor Protection

To properly select MV fuses for motor protection, several factors should be considered. R Rated fuses are only intended for short-circuit protection and should be applied in conjunction with motor overload relays. An R Rated fuse does not have an ampere rating and the “R” rating refers to the opening time of the fuse. R Rated fuses are designed to safely interrupt any current between their minimum and maximum interrupting rating. When applying R Rated fuses, it is recommended to follow the fuse sizing guidelines established by the motor starter manufacturer.

When engineering a system, time-current characteristic curves of the fuse and overload relay should be compared to insure the overload relay opens before the fuse during overload conditions. The following table is provided as a guideline for sizing R Rated fuses.

**R-Rated Fuse Sizing Table**

For Motors with an Acceleration of 10 Seconds		For Motors with an Acceleration of 3 Seconds	
Max. Motor FLA	R Rated Fuse	Max. Motor FLA	R Rated Fuse
28A	2R	32A	2R
40A	3R	45A	3R
55A	4R	65A	4R
80A	6R	95A	6R
125A	9R	140A	9R
165A	12R	190A	12R
250A	18R	280A	18R
330A	24R	360A	24R
500A	36R	550A	36R

### Transformer Protection

A principle use of MV fuses is to provide primary short-circuit protection for transformers. When selecting MV fuses to protect transformers, the following factors must be considered in descending order of importance:

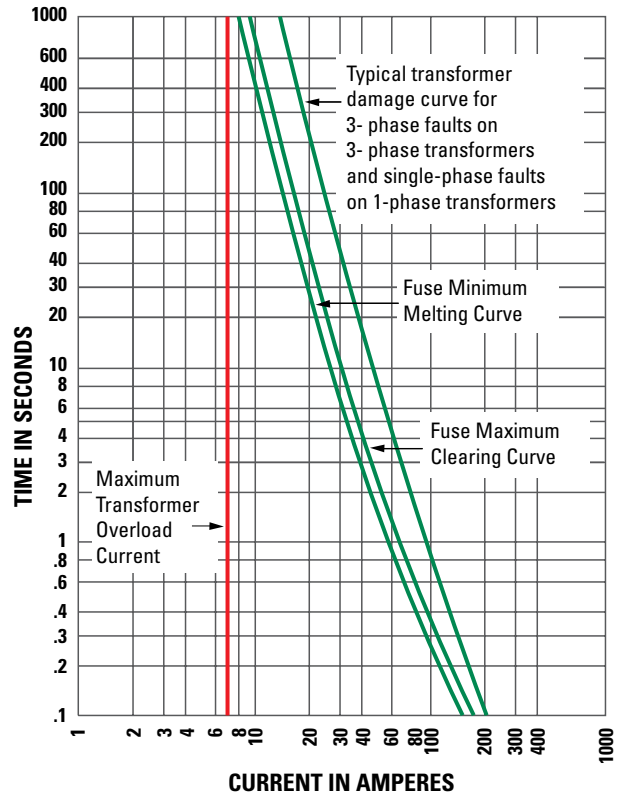

**Figure 22**

- As explained above, the fuses voltage and interrupting ratings must equal or exceed system requirements at the point where fuses will be applied.
- The fuse continuous current rating must be large enough to withstand transformer magnetizing (in-rush) current. (Minimum Fuse Rating).
- The fuse continuous current rating must be able to withstand transformer overloading and emergency operation, and meet NEC requirements. (Maximum Fuse Rating).
- Fuses must protect the system on the line side of the fuse from the effects of short circuits on the load side of the fuses. (Utility System Coordination).
- Fuses must coordinate with the transformer secondary protection where and whenever possible. (Facility System Coordination).
- Fuses must protect transformer against secondary bolted faults.
- Where and whenever possible, fuses should protect the transformer against higher impedance secondary faults.

Transformer magnetizing or inrush current depends on several factors such as transformer design, residual flux in the core at the instant the transformer is energized, the point on the voltage wave at which the switch is closed, and the characteristics of the electrical system powering the transformer. Power transformers in-rush current approximates 12 times the transformer full load current, and distribution transformers 25 to 40 times full load current. The current generally lasts less than  $\frac{1}{10}$  second.

## Fuse Application Guide

### Applying Medium Voltage Fuses

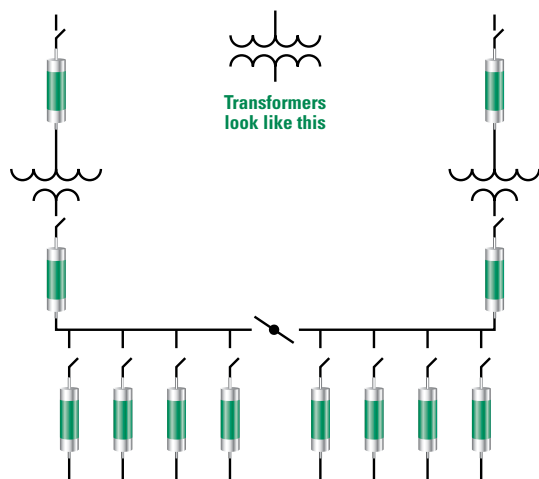

Figure 23

To determine the minimum size fuse which will hold the in-rush current, obtain the in-rush current from the transformer manufacturer and mark the current on the fuses minimum melting time-current curves at 0.10 second as shown in **Figure 22**. The minimum fuse rating is the fuse whose minimum melting curve is just to the right and above the transformer inrush point.

When the in-rush current is not greater than 12 times transformer full load current, MV fuses with current ratings that equal or exceed a transformer’s self-cooled, full load current will usually meet this

requirement. However, transformers are generally operated at close to full load current on a continuous basis, and are overloaded under emergency conditions. A typical example is a double-ended loadcenter operated with a normally open bus tie. See **Figure 23**. Each transformer is rated to carry 150% of the load on its half of the loadcenter. With loss of service to one transformer, the main switch for that line is opened, and the bus tie switch is closed shifting all load to the remaining transformer. The system is operated overloaded until the other line is back in service. If the outage will continue for a long period of time, manual load shedding can be used to control transformer overloading.

Other similar operating schemes also result in transformer overloading. As a result, MV fuses usually have continuous current ratings larger than required to withstand transformer in-rush current.

NEC® Article 450 covers transformer installations and establishes the maximum ratings of transformer overcurrent protective devices. Regarding medium voltage fuses, Article 450.3 states in part:

Overcurrent Protection of transformers shall comply with NEC Article 450.3(A) – Transformers Over 600 Volts, Nominal, and shall be provided in accordance with **Table 9**.

*NOTE: In this section, the word transformer shall mean a transformer or polyphase bank of two or more single-phase transformers operating as a single unit.*

**Table 9**  
(Based on NEC Table 450.3(A) – Maximum Rating or Setting of Overcurrent Protection for Transformers Over 600 Volts (as a Percentage of Transformer-Rated Current))

Location Limitations	Transformer Rated Impedance	Primary Protection Over 600 Volts		Secondary Protection (See Note 2)		
		Circuit Breaker (see Note 4)	Fuse Rating	Over 600 Volts		600 Volts or Less
				Circuit Breaker (see Note 4)	Fuse Rating	Circuit Breaker or Fuse Rating
Any Location	Not more than 6% (see Note 1)	600%	300%	300%	250%	125%
	More than 6% but not more than 10% (see Note 1)	400%	300%	250%	225%	125%
Supervised Locations Only (see Note 3)	Any (see Note 1)	300%	250%	Not Required	Not Required	Not Required
	Not more than 6% (see Note 5 for Secondary Protection)	600%	300%	300%	250%	250%
	More than 6% but not more than 10% (see Note 5 for Secondary Protection)	400%	300%	250%	225%	250%

- Note 1 – If the required fuse rating or breaker setting does not correspond to standard ratings/settings, the next higher rating/setting may be used.
- Note 2 – If secondary overcurrent protection is required, no more than six breakers or sets of fuses may be grouped in any one location. When multiple overcurrent devices are used, the sum of all device ratings shall not exceed the allowed value of any single device. If both breakers and fuses are used, the total of device ratings shall not exceed that if using only fuses.
- Note 3 – A “supervised location” is one where maintenance and supervision conditions ensure that only qualified persons are allowed to monitor and perform installation service on the transformer.
- Note 4 – Electronically actuated fuses set to open at a specific current shall be set and calibrated in accordance with the corresponding settings of the circuit breakers involved.
- Note 5 – Separate secondary protection is not necessary if the transformer is equipped with a coordinated thermal overload protection provided by the manufacturer.

## Motor Protection Tables

### Selection of Class RK5 (FLNR\_ID/FLSR\_ID & IDSR Series) or POWR-PRO® Class RK1 (LLNRK/LLSRK/LLSRK\_ID Series) Fuses Based on Motor Full Load Amps

#### Using AC Motor Protection Tables to Select Fuse Ratings

Time-delay RK1 and RK5 fuse ratings selected in accordance with the following recommendations also meet NEC® requirements for Motor Branch circuit and Short-Circuit Protection.

#### Selecting Fuses for Motor Running Protection Based on Motor Horsepower

Motor horsepower and motor Full Load Amperes (FLA) shown are taken from NEC Tables 430.248 through 430.250 covering standard speed AC motors with normal torque characteristics. Fuse ratings for motors with special characteristics may need to vary from given values.

If motor running protection will be provided by the fuses, select fuse ratings for correct type of motor from Motor Protection Table Columns headed, "Without Overload Relays."

If overload relays will provide principal motor running protection, select fuse ratings for correct type of motor from Motor Protection Table Columns headed, "Back-up Running Protection" or "With Overload Relays." Fuse ratings selected from these columns coordinate with most UL Class 10 and 20 overload relays which covers over 90% of motor applications.

#### Selecting Fuses for Motor Running Protection Based on Motor Actual Full Load Currents

Better protection is achieved when fuse ratings are based on motor actual FLA obtained from motor nameplates. Locate motor nameplate FLA in the column appropriate for the type of motor and type of protection required. Then select the corresponding ampere rating from the first column of that line.

Time Delay UL Class RK1 or RK5 Fuse Ampere Rating	Motor Running Protection (Used Without Properly Sized Overload Relays) Motor Full-Load Amps		Back-up Motor Running Protection (Used With Properly Sized Overload Relays) Motor Full-Load Amps	
	Motor Service Factor of 1.15 or Greater or With Temp. Rise Not over 40°C.	Motor Service Factor Less Than 1.15 or with Temp. Rise Greater Than 40°C.	Motor Service Factor of 1.15 or Greater or With Temp. Rise Not Over 40°C.	Motor Service Factor Less Than 1.15 or with Temp. Rise Greater Than 40°C.
1/10	0.08-0.09	0.09-0.10	0-0.08	0-0.09
1/8	0.10-0.11	0.11-0.125	0.09-0.10	0.10-0.11
15/100	0.12-0.15	0.14-0.15	0.11-0.12	0.12-0.13
2/10	0.16-0.19	0.18-0.20	0.13-0.16	0.14-0.17
1/4	0.20-0.23	0.22-0.25	0.17-0.20	0.18-0.22
3/10	0.24-0.30	0.27-0.30	0.21-0.24	0.23-0.26
4/10	0.32-0.39	0.35-0.40	0.25-0.32	0.27-0.35
1/2	0.40-0.47	0.44-0.50	0.33-0.40	0.36-0.43
6/10	0.48-0.60	0.53-0.60	0.41-0.48	0.44-0.52
8/10	0.64-0.79	0.70-0.80	0.49-0.64	0.53-0.70
1	0.80-0.89	0.87-0.97	0.65-0.80	0.71-0.87
1 1/8	0.90-0.99	0.98-1.08	0.81-0.90	0.88-0.98
1 1/4	1.00-1.11	1.09-1.21	0.91-1.00	0.99-1.09
1 1/2	1.12-1.19	1.22-1.30	1.01-1.12	1.10-1.22
1 3/4	1.20-1.27	1.31-1.39	1.13-1.20	1.23-1.30
1 9/10	1.28-1.43	1.40-1.56	1.21-1.28	1.31-1.39
1 10/10	1.44-1.59	1.57-1.73	1.29-1.44	1.40-1.57
2	1.60-1.79	1.74-1.95	1.45-1.60	1.58-1.74
2 1/4	1.80-1.99	1.96-2.17	1.61-1.80	1.75-1.96
2 1/2	2.00-2.23	2.18-2.43	1.81-2.00	1.97-2.17
2 9/10	2.24-2.39	2.44-2.60	2.01-2.24	2.18-2.43
3	2.40-2.55	2.61-2.78	2.25-2.40	2.44-2.60
3 1/10	2.56-2.79	2.79-3.04	2.41-2.56	2.61-2.78
3 1/2	2.80-3.19	3.05-3.47	2.57-2.80	2.79-3.04
4	3.20-3.59	3.48-3.91	2.81-3.20	3.05-3.48
4 1/2	3.60-3.99	3.92-4.34	3.21-3.60	3.49-3.91
5	4.00-4.47	4.35-4.86	3.61-4.00	3.92-4.35
5 1/10	4.48-4.79	4.87-5.21	4.01-4.48	4.36-4.87
6	4.80-4.99	5.22-5.43	4.49-4.80	4.88-5.22
6 1/4	5.00-5.59	5.44-6.08	4.81-5.00	5.23-5.43
7	5.60-5.99	6.09-6.52	5.01-5.60	5.44-6.09
7 1/2	6.00-6.39	6.53-6.95	5.61-6.00	6.10-6.52
8	6.40-7.19	6.96-7.82	6.01-6.40	6.53-6.96
9	7.20-7.99	7.83-8.69	6.41-7.20	6.97-7.83
10	8.00-9.59	8.70-10.00	7.21-8.00	7.84-8.70
12	9.60-11.99	10.44-12.00	8.01-9.60	8.71-10.43
15	12.00-13.99	13.05-15.00	9.61-12.00	10.44-13.04
17 1/2	14.00-15.99	15.22-17.39	12.01-14.00	13.05- 15.21
20	16.00-19.99	17.40-20.00	14.01-16.00	15.22-17.39
25	20.00-23.99	21.74-25.00	16.01-20.00	17.40-21.74
30	24.00-27.99	26.09-30.00	20.01-24.00	21.75-26.09
35	28.00-31.99	30.44-34.78	24.01-28.00	26.10-30.43
40	32.00-35.99	34.79-39.12	28.01-32.00	30.44-37.78
45	36.00-39.99	39.13-43.47	32.01-36.00	37.79-39.13
50	40.00-47.99	43.48-50.00	36.01-40.00	39.14-43.48
60	48.00-55.99	52.17-60.00	40.01-48.00	43.49-52.17
70	56.00-59.99	60.87-65.21	48.01-56.00	52.18-60.87
75	60.00-63.99	65.22-69.56	56.01-60.00	60.88-65.22
80	64.00-71.99	69.57-78.25	60.01-64.00	65.23-69.57
90	72.00-79.99	78.26-86.95	64.01-72.00	69.58-78.26
100	80.00-87.99	86.96-95.64	72.01-80.00	78.27-86.96
110	88.00-99.99	95.65-108.69	80.01-88.00	86.97-95.65
125	100.00-119.99	108.70-125.00	88.01-100.00	95.66-108.70
150	120.00-139.99	131.30-150.00	100.01-120.00	108.71-130.43
175	140.00-159.99	152.17-173.90	120.01-140.00	130.44-152.17
200	160.00-179.99	173.91-195.64	140.01-160.00	152.18-173.91
225	180.00-199.99	195.65-217.38	160.01-180.00	173.92-195.62
250	200.00-239.99	217.39-250.00	180.01-200.00	195.63-217.39
300	240.00-279.99	260.87-300.00	200.01-240.00	217.40-260.87
350	280.00-319.99	304.35-347.82	240.01-280.00	260.88-304.35
400	320.00-359.99	347.83-391.29	280.01-320.00	304.36-347.83
450	360.00-399.99	391.30-434.77	320.01-360.00	347.84-391.30
500	400.00-479.99	434.78-500.00	360.01-400.00	391.31-434.78
600	480.00-600.00	521.74-600.00	400.01-480.00	434.79-521.74

# Motor Protection Tables

Selection of Class RK5 (FLNR\_ID/FLSR\_ID & IDSR Series) or POWR-PRO® Class RK1 (LLNRK/LLSRK/LLSRK\_ID Series) Fuses Based on Motor Horsepower

Motor HP	Full Load Amps	Without Overload Relays		With Overload Relays		Switch or Fuse Clip Rating
		S.F. = 1.15 Or More, Temp Rise Not Over 40°C	S.F. = Less Than 1.15 Or Temp Rise More Than 40°C	S.F. = 1.15 Or More, Temp Rise Not Over 40°C	S.F. = Less Than 1.15 Or Temp Rise More Than 40°C	
<b>120 VOLT 1-PHASE MOTORS (120V CIRCUIT)</b>						
1/6	4.4	5	5	5 <sup>1/10</sup>	5 <sup>1/10</sup>	30
1/4	5.8	7	6 <sup>1/4</sup>	7 <sup>1/2</sup>	7	30
1/3	7.2	9	8	9	9	30
1/2	9.8	12	10	15	12	30
3/4	13.8	15	15	17 <sup>1/2</sup>	17 <sup>1/2</sup>	30
1	16	20	17 <sup>1/2</sup>	20	20	30
1 1/2	20	25	20	25	25	30
2	24	30	25	30	30	30
<b>230 VOLT 1-PHASE MOTORS (240V CIRCUIT)</b>						
1/6	2.2	2 <sup>1/2</sup>	2 <sup>1/2</sup>	2 <sup>1/10</sup>	2 <sup>1/10</sup>	30
1/4	2.9	3 <sup>1/2</sup>	3 <sup>1/2</sup>	4	3 <sup>1/2</sup>	30
1/3	3.6	4 <sup>1/2</sup>	4	4 <sup>1/2</sup>	4 <sup>1/2</sup>	30
1/2	4.9	5 <sup>1/10</sup>	5 <sup>1/10</sup>	6 <sup>1/4</sup>	6	30
3/4	6.9	8	7 <sup>1/2</sup>	9	8	30
1	8	10	9	10	10	30
1 1/2	10	12	10	15	12	30
2	12	15	12	15	15	30
3	17	20	17 <sup>1/2</sup>	25	20	30
5	28	35	30*	35	35	60
7 1/2	40	50	45	50	50	60
10	50	60	50	70	60	60
<b>200 VOLT 3-PHASE MOTORS (208V CIRCUIT)</b>						
1/2	2.5	3	2 <sup>1/10</sup>	3 <sup>1/10</sup>	3	30
3/4	3.7	4 <sup>1/2</sup>	4	5	4 <sup>1/2</sup>	30
1	4.8	6	5 <sup>1/10</sup>	6 <sup>1/4</sup>	6	30
1 1/2	6.9	8	7 <sup>1/2</sup>	7 <sup>1/2</sup>	8	30
2	7.8	9	8	10	9	30
3	11	12	12	15	15	30
5	17.5	20	20	25	25	30
7 1/2	25.3	30*	25*	35	30*	60
10	32.2	40	35	45	40	60
15	48.3	60	50	70†	60	60
20	62.1	75	70	80	75	100
25	78.2	90	80	100	90	100
30	92	110	100*	125	110	200
40	120	150	125	150	150	200
50	150	175	150	200	175	200
60	177	200*	200*	225	225	400
75	221	250	250	300	300	400
100	285	350	300	400	350	400
125	359	400*	400*	450	450	600
150	414	500	450	600	500	600
<b>230 VOLT 3-PHASE MOTORS (240V CIRCUIT)</b>						
1/2	2.2	2 <sup>1/10</sup>	2 <sup>1/2</sup>	2 <sup>1/10</sup>	2 <sup>1/10</sup>	30
3/4	3.2	4	3 <sup>1/2</sup>	4	4	30
1	4.2	5	4 <sup>1/2</sup>	5 <sup>1/10</sup>	5	30
1 1/2	6.0	7 <sup>1/2</sup>	6 <sup>1/4</sup>	7 <sup>1/2</sup>	7 <sup>1/2</sup>	30
2	6.8	8	7 <sup>1/2</sup>	9	8	30
3	9.6	12	10	12	12	30
5	15.2	17 <sup>1/2</sup>	17 <sup>1/2</sup>	20	17 <sup>1/2</sup>	30
7 1/2	22	25	25	30	30	30
10	28	35	30*	35	35	60
15	42	50	45	60	50	60
20	54	60*	60*	70	70	100
25	68	80	75	90	80	100
30	80	100	90	100	100	100
40	104	125	110	150	125	200
50	130	150	150	175	150	200
60	154	175	175	200	200	200
75	192	225	200*	250	225	400
100	248	300	250	350	300	400
125	312	350	350	400	400	400
150	360	450	400*	450	450	600
200	480	600	500	600	600	600

Motor HP	Full Load Amps	Without Overload Relays		With Overload Relays		Switch or Fuse Clip Rating
		S.F. = 1.15 Or More, Temp Rise Not Over 40°C	S.F. = Less Than 1.15 Or Temp Rise More Than 40°C	S.F. = 1.15 Or More, Temp Rise Not Over 40°C	S.F. = Less Than 1.15 Or Temp Rise More Than 40°C	
<b>460 VOLT 3-PHASE MOTORS (480V CIRCUIT)</b>						
1/2	1.1	1 <sup>1/10</sup>	1 <sup>1/4</sup>	1 <sup>1/10</sup>	1 <sup>1/10</sup>	30
3/4	1.6	2	1 <sup>1/10</sup>	2	2	30
1	2.1	2 <sup>1/2</sup>	2 <sup>1/4</sup>	2 <sup>1/10</sup>	2 <sup>1/2</sup>	30
1 1/2	3.0	3 <sup>1/2</sup>	3 <sup>3/10</sup>	4	3 <sup>1/2</sup>	30
2	3.4	4	3 <sup>1/2</sup>	4 <sup>1/2</sup>	4	30
3	4.8	5 <sup>1/10</sup>	5	6	5 <sup>1/10</sup>	30
5	7.6	9	8	10	9	30
7 1/2	11	12	12	15	15	30
10	14	17 <sup>1/2</sup>	15	17 <sup>1/2</sup>	17 <sup>1/2</sup>	30
15	21	25	20	30	25	30
20	27	30*	30*	35	35	60
25	34	40	35	45	40	60
30	40	50	45	50	50	60
40	54	60*	60*	70	60*	100
50	65	80	70	90	75	100
60	77	90	80	100	90	100
75	96	110	110	125	125	200
100	124	150	125	175	150	200
125	156	175	175	200	200	200
150	180	225	200*	225	225	400
200	240	300	250	300	300	400
<b>575 VOLT 3-PHASE MOTORS (600V CIRCUIT)</b>						
1/2	0.9	1 <sup>1/8</sup>	1	1 <sup>1/8</sup>	1 <sup>1/8</sup>	30
3/4	1.3	1 <sup>1/10</sup>	1 <sup>1/10</sup>	1 <sup>1/10</sup>	1 <sup>1/10</sup>	30
1	1.7	2	1 <sup>1/10</sup>	2 <sup>1/4</sup>	2	30
1 1/2	2.4	3	2 <sup>1/2</sup>	3	3	30
2	2.7	3 <sup>1/10</sup>	2 <sup>1/10</sup>	3 <sup>1/2</sup>	3 <sup>1/10</sup>	30
3	3.9	4 <sup>1/2</sup>	4	5	4 <sup>1/2</sup>	30
5	6.1	7 <sup>1/2</sup>	7	8	7 <sup>1/2</sup>	30
7 1/2	9	10	10	12	12	30
10	11	12	12	15	15	30
15	17	20	17 <sup>1/2</sup>	25	20	30
20	22	25	25	30	30	30
25	27	30*	30*	35	35	60
30	32	40	35	40	40	60
40	41	50	45	60	50	60
50	52	60	60	70†	60	60
60	62	75	70	80	75	100
75	77	90	80	100	90	100
100	99	110	110	125	125	200
125	125	150	125	175	150	200
150	144	175	150	200	175	200
200	192	225	200*	250	225	400

**NOTES**  
 S.F. = Motor Service Factor  
 \* Fuse Reducers Required  
 † 100 Amp Switch Required

## Motor Protection Tables

### Selection of POWR-PRO® Class J (JTD\_ID/JTD Series) Fuses Based on Motor Full Load Amps

Motor F.L.A.	JTD_ID/JTD Ampere Rating	Motor F.L.A.	JTD_ID/JTD Ampere Rating	Motor F.L.A.	JTD_ID/JTD Ampere Rating
0.00 – 0.60	5/10	12.1 – 14.5	17 1/2	76.1 – 84.0	110
0.61 – 0.80	1	14.6 – 17.0	20	84.1 – 90.0	125
0.81 – 1.00	1 1/4	17.1 – 21.0	25	90.1 – 102	150
1.01 – 1.20	1 1/2	21.1 – 25.0	30	103 – 125	175
1.21 – 1.65	2	25.1 – 28.5	35	126 – 144	200
1.66 – 2.00	2 1/2	28.6 – 34.0	40	145 – 162	225
2.01 – 2.40	3	34.1 – 37.0	45	163 – 180	250
2.41 – 3.30	4	37.1 – 41.0	50	181 – 204	300
3.31 – 4.10	5	41.1 – 48.0	60	205 – 240	350
4.11 – 4.90	6	48.1 – 52.0	70	241 – 288	400
4.91 – 6.40	8	52.1 – 59.0	80	289 – 312	450
6.41 – 8.00	10	59.1 – 66.0	90	313 – 360	500
8.01 – 9.80	12	66.1 – 76.0	100	361 – 432	600
9.81 – 12.0	15				

NOTE: For severe motor starting conditions, fuses may be sized up to 225% motor F.L.A. (See NEC Article 430.52 for Exceptions)

### Selection of CCMR Time-Delay Fuses Based on Motor Full Load Amps

Motor Full Load Current (F.L.A.)						CCMR Ampere Rating
For Motors With An Acceleration Time Of 2 Seconds Or Less		For Motors With An Acceleration Time Of 5 Seconds Or Less		For Motors With An Acceleration Time Of 8 Seconds Or Less		
Min. F.L.A. (1)	Max F.L.A. (3)	Min. F.L.A. (1)	Max F.L.A. (3)	Min F.L.A. (2)	Max F.L.A. (3)	
0.2	0.2	0.2	0.2	0.2	0.2	3/10
0.3	0.4	0.3	0.4	0.3	0.3	1/2
0.4	0.6	0.4	0.5	0.4	0.5	5/10
0.5	0.7	0.5	0.6	0.5	0.6	1
0.6	1.0	0.6	0.9	0.6	0.8	1 1/4
0.8	1.1	0.8	1.0	0.7	0.9	1 1/2
0.9	1.3	0.9	1.1	0.8	1.0	1 9/10
1.1	1.4	1.1	1.2	0.9	1.1	2
1.2	2.1	1.2	2.1	1.2	1.8	2 1/2
1.5	2.6	1.5	2.6	1.4	2.3	3
1.8	3.0	1.8	3.0	1.6	2.6	3 1/2
2.1	3.4	2.1	3.2	1.8	2.8	4
2.3	3.9	2.3	3.3	2.0	2.8	4 1/2
2.6	4.3	2.6	3.4	2.3	2.8	5
2.9	4.8	2.9	3.7	2.5	3.1	5 5/10
3.3	5.2	3.3	4.0	2.7	3.4	6
3.5	5.4	3.5	4.1	2.8	3.5	6 1/4
3.6	5.7	3.6	4.2	3.2	3.7	7
4.1	5.8	4.1	4.3	3.4	3.8	7 1/2
4.3	6.2	4.3	4.6	3.6	4.2	8
4.6	6.9	4.6	5.2	4.0	4.5	9
5.2	7.7	5.2	5.8	4.5	4.9	10
5.8	8.9	5.8	6.6	5.4	5.5	12
6.9	10.0	6.9	7.7	6.7	6.7	15
8.9	13.5	8.9	10.0	6.8	9.0	20
11.5	15.8	11.2 (2)	11.8	9.0	11.0	25
14.3	17.8	13.4 (2)	13.4	10.0	15.0	30
20.7	23.3	16.1	17.9	15.6	15.9	35
23.7	26.7	18.4	20.5	17.8	18.2	40
26.6	30.0	20.7	23.1	20.0	20.4	45
30.0	33.3	23.0	25.6	22.3	22.7	50
35.5	40.0	27.6	30.1	26.7	27.3	60

- 1 Based on NEC requirement limiting the rating of time-delay fuses to 175% of motor F.L.A., or next higher rating.
- 2 Based on NEC exception permitting fuse rating to be increased, but not to exceed, 225% motor F.L.A., however per NEC Article 430.52 Class CC (0-30) fuses can now be sized up to 300% of motor F.L.A.
- 3 Based on Littelfuse CCMR time-delay characteristics.

NOTE: These values were calculated for motors with Locked Rotor Current (LRA), not exceeding the following values:

Motor F.L.A.	*LRA
0.00 – 1.00	850%
1.01 – 2.00	750%
2.01 – 10.0	650%
10.1 – 17.8	600%

\*If motor LRA varies from these values, contact Littelfuse.

## Condensed Cross Reference

### Power/Electronic Fuses

This cross reference covers most popular fuses for which there is a similar Littelfuse standard item. Furnished for your convenience, it is meant to serve as a guide only for product selection. We suggest you check all applicable specifications before making substitutions. For special applications, consult the factory.

For more complete information, and for fuse block and medium voltage fuse cross referencing, send for Cross Reference Booklet EC501 or call 1-800-TEC-FUSE (1-800-832-3873).

Competition	Littelfuse	Competition	Littelfuse	Competition	Littelfuse	Competition	Littelfuse
10KOTN	NLN	CLL	KLLU or KLPC	JHC	JTD_ID	NCLR	KLNR
10KOTS	NLS	CLU	KLLU or KLPC	JJN	JLLN	NON	NLN
50KOTN	NLN	CM	BLF	JJS	JLLS	NOS	NLS
50KOTS	NLS	CMF	BLN	JKS	JLS	NRN	NLN
A	251	CNM	FLM	KAA	L15S	NRN (15-60A)	NLKP
A013F	L15S	CNQ	FLQ	KAB	L25S	NRS	NLS
A015F	L15S	CRN-R	FLNR_ID (note 3)	KAC	KLC	OT	NLN
A015R	L15S	CRS-R	FLSR_ID	KBH	L50S	OTM	BLF or BLN
A025F	L25S	CSF13X	L15S	KLM	KLKD	OTN	NLN
A050F	L50S	CSF25X	L25S (AC only)	KLMR	CCMR	OTS	NLS
A060F	L60S	CSF50P	L50S	KLU	KLLU or KLPC	REN	RLN
A060URL	KLK	CSF60C	KLC (AC only)	KN	KLNR	RES	RLS
A070F	L70S	CSF60X	L60S (AC only)	KON	NLN	RF	RLN
A13X	L15S	CSF70P	L70S	KOS	NLS	RFA	L15S
A25X	L25S (AC only)	CTN-R	KLNR	KRPC (SP)	KLPC	RFC	KLC
A2D-R	LLNRK	CTS-R	KLSR	KRPC-L	KLPC	RFL (750V)	L70S (700V)
A2K-R	KLNR	EBS	BLS	KS	KLSR	RFN (Ferraz)	RLN
A3T	JLLN	ECNR	FLNR_ID (note 3)	KTK	KLK	RFS (Ferraz)	RLS
A4BQ	KLPC	ECSR	FLSR_ID	KTKR	KLKR	RFV	L50S
A4BT	KLLU or KLPC	ELN	LKN	KTNR	KLNR	RHN	KLNR
A4BY	KLPC or KLLU	ELS	LKS	KTSR	KLSR	RHS	KLSR
A4J	JLS	ERN	RLN	KTU	KLPC	RLN (Ferraz)	LKN
A50P (type 1 & 4)	L50S	ERS	RLS	L	KLLU or KLPC	RLS (Ferraz)	LKS
A60X	L60S	FNA	FLA	LCL	KLPC or KLLU	S	SOO
A6D-R	LLSRK_ID	FNB	235	LCU	KLPC or KLLU	SA	SAO
A6K-R	KLSR	FNM	FLM	LENRK	LLNRK	SC	SLC
A6T	JLLS	FNQ	FLQ	LESRK	LLSRK_ID	SCLR	KLSR
A70P	L70S	FNQ-R	KLDR	LKN	LKN	SEC	SLC
ACK	CCK	FRN-R	FLNR_ID (note 3)	LKS	LKS	SF13X	L15S
AG	SLC	FRS-R	FLSR_ID	LKU	KLLU	SF25X	L25S
AGA	AGA	FWA (note 2)	L15S	LONRK	LLNRK	SF50P	L50S
AGC	312	FWH (note 2)	L50S	LOSrk	LLSRK_ID	SF60X	L60S
AGU (1-30A)	BLN	FWP (note 1)	L70S	LPCC	CCMR	SF70P	L70S
AGW	AGW	FWX (note 1)	L25S	LPJ (SP)	JTD_ID	SFE	SFE
AJT	JTD_ID	GDA	216	LPNRK (SP)	LLNRK	SL	SLO
ANL	CNL	GDB	217	LPSRK (SP)	LLSRK_ID	T	TOO
ANN	CNN	GDC	218	MCL	KLK	TJN	JLLN
ATC	ATO (257)	GDL	313	MDA	326	TJS	JLLS
AT-DE	FLNR_ID (note 3)	GEB	LEB	MDL	313	TL	TLO
ATDR	CCMR	GEBN	LET	MDO	313	TR	FLNR_ID (note 3)
ATM	KLK	GFA	251	MDV	315	TRM	FLM
ATMR	KLKR	GFN	FLA	MDX	313	TRN-R	FLNR_ID (note 3)
ATQ	FLQ	GGC	312	MEN	FLM	TRS	FLSR_ID
ATQR	KLDR	GGM	235	MEQ	FLQ	TRS-R	FLSR_ID
AX	481	GLR	LGR	MID	FLA	XL25X	L25S
AXRAD	252	GMT	481	MOF	BLN	XL50F	L50S (note 1)
BAF	BLF	HCLR	KLKR	MOL	BLF	XL70F	L70S (note 1)
BAN	BLN	HCTR	KLDR	MTH	312		
BBS	BLS	HEB	LEB				
CGL (2-100A)	2CO	HET	LET				
CGL (125-600A)	2CC	HLR	LHR				
CJ	JLS	J	JLS				
CJS	JLS	JDL	JTD_ID				
CLF	KLPC or KLLU	JFL	JLS				

1) Check specific mounting dimensions before substituting.  
 2) Check fuse characteristics and mounting dimensions for specific application before substituting.  
 3) For 1/10 - 30 amperes, order non-indicating FLNR series fuses.  
 Remember a fuse may be used in circuits where the fuse's voltage rating is equal to or greater than the circuit voltage, unless otherwise stated on the fuse. For example, the FLSR\_ID indicating fuse has a voltage rating of 75-600 volts. This fuse can be used on 600 volts, 480 volts, 250 volts, 125 volts, or 75 volts. Never use a fuse in a circuit having higher rated voltage than the fuse.

## Alphanumeric Index of Catalog Numbers

Catalog Number	Page Number	Catalog Number	Page Number	Catalog Number	Page Number	Catalog Number	Page Number
Arc-Flash	177	KLKR series	45-47	LPMP series	154-155	SLC series	44
ATO series	60	KLLU series	26-28	LPS1	152-153	SLO series	48
BLF series	51	KLNR series	34-35	LPS2	152-153	S00 series	48
BLN series	51	KLPC series	8-10	LPS3	152-153	SPL001	127
BLS series	52	KLQ series	53	LPS4	152-153	Splicer Blocks	137-144
Box Cover Units	158-159	KLSR series	34-35	LPS6	152-153	Suppression	170-174
CablePro®	62	L15S series	85-86	LPSC series	128	Telecom Fuses	76-80
CBO series	107	L17T series	77	LPSG series	163	TLN series	78
CCK series	107	L25S series	85-86	LPSJ series	129	TLO series	48
CCL series	107	L30030G series	124	LPSM series	128	TLS series	79
CCMR series	20-21, 45-47	L50S series	85-86	LR250 series	112-116	TMOV	173
Class CC	20-21, 45-47	L60030C series	125-126	LR600 series	112-116	T00 series	48
Class CD	20-21, 45-47	L60030M series	125-126	LRU series	157	US3J series	129
Class G	44	L60060C series	125-126	LS series	137-144	US6J series	129
Class H	38	L60S series	85, 87	LSCR series	134	WPB series	147
Class J	17-19, 39-40	L70S series	85, 87	LSCY	158-159	094324PG	160
Class K5	36-37	LA15QS	88-89	LSFC	160	215 series	57
Class L	8-10, 23-24, 26-28	LA30QS	90-91	LSKA	158-159	216 series	57
		LA50QS	92-93	LSOU	158-159	217 series	57
Class RK1	11-16, 34-35	LA60QS	94	LSOW	158-159	218 series	57
Class RK5	22, 29-33	LA60X	95	LSOX	158-159	224 series	58
Class T	41-43	LA70QS	96-98	LSOY	158-159	225 series	58
CNL series	107	LA100P	99-100	LSOY-B	158-159	229 series	56
CNN series	107	LA120X	101	LSRU	158-159	230 series	56
CYHP001	128, 168	LA070URD	102-104	LSRW	158-159	235 series	58
Cylindrical Fuses	168	LA130URD	102, 105-106	LSRX	158-159	239 series	58
Diazed Fuses	166-167	LCC series	131	LSRY	158-159	251 series	59
Definitions	177-181	LD series	137-144	LSSU	158-159	252 series	59
Distribution Blocks	137-144	LDC series	23-24	LSSW	158-159	257 series	see ATO
Electrical Safety	182-183	LEB series	145-150	LSSX	158-159	272 series	59
Electronic Fuses	55-59	LEC series	145-150	LSSY-L	158-159	273 series	59
E-Rated Fuses	69-74	LET series	145-150	LSSY-RL	158-159	278 series	59
European Fuses	161-169	LEX series	145-150	LSTY	158-159	279 series	59
FBDIN1	127	LEY series	145-150	LT300 series	120-123	297 series	see MIN
FDR001PG	160	LFCL series	108	LT600 series	120-123	299 series	see MAX
FLA series	52	LFDS series	156	LTFD series	81-82	2CC series	169
FLM series	50	LFFB001	133	LVSP series	174	2CM series	169
FLNR series	33	LFFS030CC	156	MAX series	60	2C0 series	169
FLNR_ID series	29-32	LG300 series	124	Medium Voltage	63-75	312 series	55
FLQ series	51	LgD series	5, 162	MEGA series	61	313 series	55
FLSR series	33	LGR series	109	MFP	131	313_ID series	56
FLSR_ID series	29-32	Live Parts	75	MIDI series	61	314 series	55
FLU series	53	LH250 series	112-116	MIN series	60	315 series	55
Fuse Blocks	126	LH250-PC series	130	MOV	173	318 series	55
Fuseology	172-206	LH600 series	112-116	MROplus	6	324 series	55
Fuse Reducers	157	LH600-PC series	130	Neozed Fuses	166-167	325 series	55
GFP	131	LHFB	133	NH Fuse Links	164-165	326 series	55
IDSR series	22	LHR series	108	NLKP series	36-37	334 series	56
ILS series	135-136	LJ600 series	117-119	NLN series	36-37	473 series	59
Inline Fuseholders	145-150	LJ600-PC series	130	NLS series	36-37	481 series	80
JCASE series	62	LKN series	38	Overvoltage	170-174	496 series	62
JLLN series	41-43	LKS series	38	Plug Fuses	48	498 series	61
JLLS series	41-43	LLNRK series	14-16	PT Fuses	74	571 series	132
JLS series	39-40	LLSRK series	14-16	RLN series	38	572 series	132
JTD_ID series	17-19	LLSRK_ID series	11-13	RLS series	38	70 series	80
KLC series	85, 87	LMF series	109	R-Rated Fuses	65-68	700 series	75
KLDR series	45-47	LNNB	53	SAO series	48		
KLK series	50	LPFP	131	Semiconductor Fuses	83-106		
KLKD series	50	LPBC series	138	SFE series	60		